

CERN-EP-2019-014  
2019/04/05

CMS-BPH-18-007

# Observation of two excited $B_c^+$ states and measurement of the $B_c^+(2S)$ mass in pp collisions at $\sqrt{s} = 13$ TeV

The CMS Collaboration\*

## Abstract

Signals consistent with the  $B_c^+(2S)$  and  $B_c^{*+}(2S)$  states are observed in proton-proton collisions at  $\sqrt{s} = 13$  TeV, in an event sample corresponding to an integrated luminosity of  $143 \text{ fb}^{-1}$ , collected by the CMS experiment during the 2015–2018 LHC running periods. These excited  $\bar{b}c$  states are observed in the  $B_c^+ \pi^+ \pi^-$  invariant mass spectrum, with the ground state  $B_c^+$  reconstructed through its decay to  $J/\psi \pi^+$ . The two states are reconstructed as two well-resolved peaks, separated in mass by  $29.1 \pm 1.5 (\text{stat}) \pm 0.7 (\text{syst}) \text{ MeV}$ . The observation of two peaks, rather than one, is established with a significance exceeding five standard deviations. The mass of the  $B_c^+(2S)$  meson is measured to be  $6871.0 \pm 1.2 (\text{stat}) \pm 0.8 (\text{syst}) \pm 0.8 (B_c^+) \text{ MeV}$ , where the last term corresponds to the uncertainty in the world-average  $B_c^+$  mass.

*Published in Physical Review Letters as doi:10.1103/PhysRevLett.122.132001.*

arXiv:1902.00571v3 [hep-ex] 3 Apr 2019



The  $B_c$  family consists of charged mesons composed of a beauty quark and a charm antiquark (or vice-versa). The ground state was discovered in 1998 by the CDF Collaboration [1]. The spectrum of this heavy quarkonium family is predicted to be very populated [2–13], but spectroscopic observations and measurements of production properties remain scarce. Indeed, their production yields are significantly smaller than those of the charmonium and bottomonium states, the  $\bar{b}c$  production cross sections being proportional to the fourth power of the strong coupling constant,  $\alpha_s^4$  (since two pairs of heavy quarks need to be produced). While the masses and sizes of these beauty-charm quark-antiquark pairs place them between the charmonium and bottomonium systems, so that many properties can be theoretically inferred by interpolation of existing knowledge, the unequal quark masses and velocities could lead to more complex dynamics, where some (nonrelativistic) approximations might break down. Since the  $\bar{b}c$  mesons cannot annihilate into gluons, the excited states decay to the ground state via the cascade emission of photons or pion pairs, leading to total widths that are less than a few hundred keV. Figure 1 shows the transitions between the lightest  $B_c$  states.

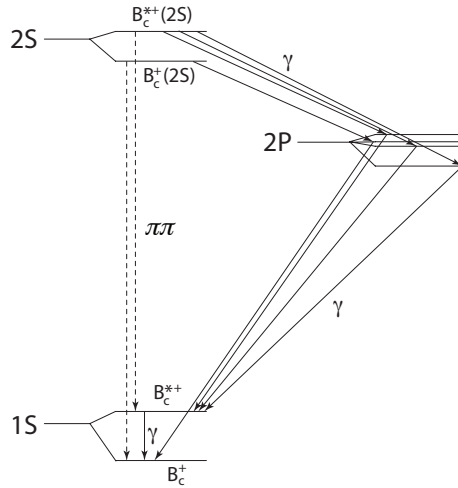

Figure 1: Transitions between the lightest  $B_c$  states, with solid and dashed lines indicating the emission of photons and pion pairs, respectively [2].

The high collision energies and integrated luminosities provided by the LHC have opened the way for a series of new measurements. The ATLAS Collaboration observed a state with a mass  $(6842 \pm 4 \text{ (stat)} \pm 5 \text{ (syst)}) \text{ MeV}$  consistent with the values predicted for the  $B_c^+(2S)$ , using data collected at 7 and 8 TeV [14], while the LHCb Collaboration reported that their 8 TeV data sample did not show any significant sign of the  $B_c^+(2S)$  or  $B_c^{*+}(2S)$  states [15]. The peak observed by ATLAS could be the superposition of the  $B_c^+(2S)$  and  $B_c^{*+}(2S)$  states, too closely spaced with respect to the resolution of the measurement. The mass difference between the  $B_c^{*+}$  and  $B_c^+$  hyperfine partners is predicted to be around 55 MeV, while the corresponding difference between the  $B_c^{*+}(2S)$  and  $B_c^+(2S)$  masses should be around 35 MeV [11–13].

While the  $B_c^+(2S)$  decays directly to  $B_c^+ \pi^+ \pi^-$ , the  $B_c^{*+}(2S)$  is expected to decay predominantly to  $B_c^{*+} \pi^+ \pi^-$ , followed by the  $B_c^{*+} \rightarrow B_c^+ \gamma$  decay. The emitted photon has a very low energy and its detection is very challenging, so that the  $B_c^{*+}(2S)$  peak should be seen in the  $B_c^+ \pi^+ \pi^-$  mass spectrum at the mass  $M(B_c^+(2S)) - \Delta M$ , where  $\Delta M \equiv [M(B_c^{*+}) - M(B_c^+)] - [M(B_c^{*+}(2S)) - M(B_c^+(2S))]$ . If the  $\Delta M$  value is larger than the experimental resolution, the  $B_c^+ \pi^+ \pi^-$  invariant mass distribution will show a two-peak structure. Since  $M(B_c^{*+}) - M(B_c^+)$  is predicted to be larger than  $M(B_c^{*+}(2S)) - M(B_c^+(2S))$ , the  $B_c^{*+}(2S)$  state will be the lower mass peak.

This Letter reports the observation of well-resolved signals consistent with the  $B_c^+(2S)$  and  $B_c^{*+}(2S)$  states, as well as the first measurement of the  $B_c^+(2S)$  mass. Although strictly speaking

we should refer to these two signals as  $B_c^+(2S)$  and  $B_c^{*+}(2S)$  candidates, in the remainder of the text we will skip the word candidates for improved readability. The result is based on the analysis of proton-proton data samples collected by the CMS experiment at a center-of-mass energy of 13 TeV, in 2015, 2016, 2017, and 2018 (the full LHC Run 2), corresponding to integrated luminosities of 2.8, 36.1, 42.1, and  $61.6 \text{ fb}^{-1}$ , respectively.

The central feature of the CMS apparatus is a superconducting solenoid of 6 m internal diameter, providing a magnetic field of 3.8 T. Within the solenoid volume are a silicon pixel and strip tracker, a lead tungstate crystal electromagnetic calorimeter, and a brass and scintillator hadron calorimeter, each composed of a barrel and two endcap sections. Forward calorimeters extend the pseudorapidity coverage provided by the barrel and endcap detectors. Muons are detected in gas-ionization chambers embedded in the steel flux-return yoke outside the solenoid. A more detailed description of the CMS detector, together with a definition of the coordinate system used and the relevant kinematic variables, can be found in Ref. [16].

The event samples used in this analysis were collected with a two-level trigger system [17]. The first level consists of custom hardware processors and uses information from the muon system to select events with two muons. The high-level trigger requires two oppositely charged muons with pseudorapidity  $|\eta| < 2.5$  and transverse momentum  $p_T > 4 \text{ GeV}$ , a distance of closest approach between the two muons smaller than 0.5 cm, a dimuon vertex fit  $\chi^2$  probability larger than 10%, a dimuon invariant mass in the range 2.9–3.3 GeV, and a distance between the dimuon vertex and the beam axis larger than three times its uncertainty. In addition, the dimuon  $p_T$  must be aligned with the transverse displacement vector:  $\cos \theta > 0.9$ , where  $\cos \theta = \vec{L}_{xy} \cdot \vec{p}_T / (L_{xy} p_T)$ , with  $\vec{L}_{xy}$  representing the transverse decay displacement vector of the dimuon. Finally, there must exist a third track in the event compatible with being produced at the dimuon vertex. The offline reconstruction requires two oppositely charged muons matching those that triggered the detector readout, with some requirements being stricter than at the trigger level, such as  $|\eta| < 2.4$  and  $\cos \theta > 0.98$ . The muons must fulfill the “soft muon identification” requirements [18] and be close to each other in angular space:  $\sqrt{(\Delta\eta)^2 + (\Delta\phi)^2} < 1.2$ , where  $\Delta\eta$  and  $\Delta\phi$  are differences in pseudorapidity and azimuthal angle, respectively, between the directions of the two muons.

Several simulated samples were used in the analysis. The  $B_c^+$ ,  $B_c^+(2S)$ , and  $B_c^{*+}(2S)$  signal samples are generated with the BCVEGPy 2.2 [19] Monte Carlo generator, interfaced with the PYTHIA 8.230 package [20] to simulate the hadronization step, and with EVTGEN 1.6.0 [21] for the decays. Final-state radiation is modeled with PHOTOS 3.61 [22]. The generated events are then processed through a detailed simulation of the CMS detector, based on the GEANT4 package [23], using the same trigger and reconstruction algorithms as used for the collision data. The simulated events include multiple proton-proton interactions in the same or nearby beam crossings, with a distribution matching the measured one. Charge-conjugated states are implied throughout this Letter.

All the physics objects used in this analysis, including the muon tracks, must pass high-purity track quality requirements [24]. The  $B_c^+$  candidates are reconstructed by combining the dimuon with a track, assumed to be a pion. This track must have at least one hit in the pixel layers, at least five hits in the tracker (pixel and strip layers), an impact parameter in the transverse plane larger than two times its uncertainty,  $|\eta| < 2.4$ , and  $p_T > 3.5 \text{ GeV}$ . The  $B_c^+$  candidate is obtained by performing a kinematic fit, imposing a common vertex on the dimuon and pion tracks, and constraining the dimuon invariant mass to be the world-average  $J/\psi$  mass [25]. The primary vertex (PV) associated with the candidate  $B_c^+$  is selected among all the reconstructed vertices [26] as the one with the smallest angle between the reconstructed  $B_c^+$  momentum and

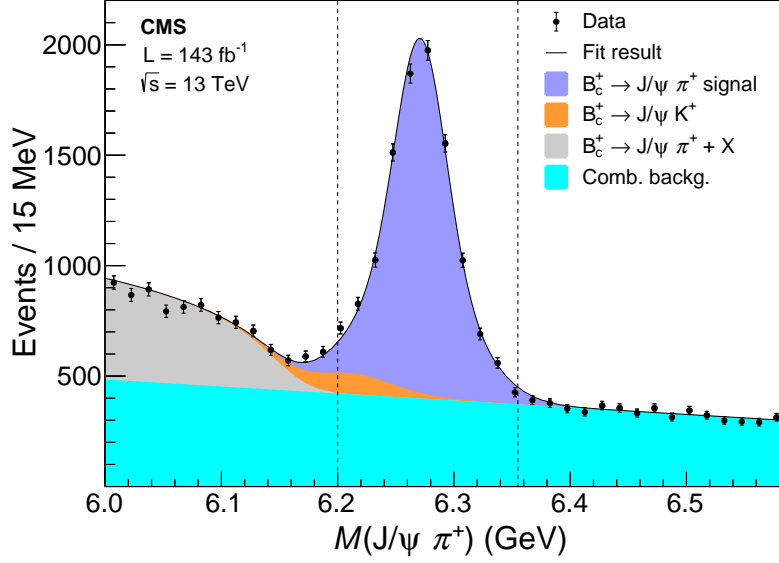

Figure 2: The invariant mass distribution of the  $B_c^+$  candidates. The vertical dashed lines indicate the mass window retained for the reconstruction of the  $B_c^+(2S)$  and  $B_c^{*+}(2S)$  candidates. The vertical bars on the points represent the statistical uncertainty in the data. The contributions from various sources are shown by the stacked distributions. The solid line represents the result of the fit.

the vector joining the PV with the  $B_c^+$  decay vertex. Studies based on simulation show that the probability of selecting a wrong vertex is less than 1%. The decay length of the  $B_c^+$ , denoted by  $l$ , is computed as the (three-dimensional) distance between the PV and the  $J/\psi \pi^+$  vertex (assumed to be, respectively, the  $B_c^+$  production and decay vertices). To avoid biases in the determination of  $l$ , the PV is refitted without the tracks associated with the muons and the pion.

Similarly to what has been previously done in Refs. [27, 28], the  $B_c^+$  candidates are required to have  $p_T > 15$  GeV, rapidity  $|y| < 2.4$ ,  $l > 100 \mu\text{m}$ , and a kinematic fit  $\chi^2$  probability larger than 10%. If several  $B_c^+$  candidates are found in the same event, only the one with the highest  $p_T$  is kept. The invariant mass distribution of the selected  $B_c^+ \rightarrow J/\psi \pi^+$  candidates, shown in Fig. 2, is fitted to the expected  $B_c^+$  signal peak, modeled as a sum of two Gaussian functions with a common mean, superimposed on a background composed of three sources of events: i) the combinatorial background resulting from associating the  $J/\psi$  with uncorrelated charged particles, parametrized by a first-order Chebyshev polynomial function; ii) partially reconstructed  $B_c^+$  decays,  $B_c^+ \rightarrow J/\psi \pi^+ X$ , only relevant for mass values below 6.2 GeV, described by a (generalized) ARGUS function [29] convolved with a Gaussian resolution function; iii) a small contribution from  $B_c^+ \rightarrow J/\psi K^+$  decays, with a shape determined from simulation studies and a normalization fixed relative to the  $B_c^+ \rightarrow J/\psi \pi^+$  yield, using the ratio of their branching fractions [30] and the ratio of the reconstruction efficiencies. The unbinned maximum-likelihood fit gives a  $B_c^+$  signal yield of  $7629 \pm 225$  events, a  $B_c^+$  mass of  $M(B_c^+) = 6271.1 \pm 0.5$  MeV, and a mass resolution of  $33.5 \pm 2.5$  MeV, where the uncertainties are statistical only. The measured mass resolution is consistent with the value expected from the simulation studies. The quality of the fit was evaluated by computing the  $\chi^2$  between the binned distribution and the fit function, the result being  $\chi^2 = 35$  for 30 degrees of freedom.

The  $B_c^+(2S)$  and  $B_c^{*+}(2S)$  candidates are reconstructed by performing a kinematic fit, combining a  $B_c^+$  candidate with two opposite-sign tracks and imposing a common vertex. Only  $B_c^+$  candidates with invariant mass in the range 6.2–6.355 GeV are selected. This mass window,

indicated in Fig. 2, reflects the measured  $B_c^+$  mass and resolution, with a low-mass edge that, while corresponding to a smaller peak coverage than the high-mass edge, suppresses the contamination from partially reconstructed decays. The lifetimes of the  $B_c^+(2S)$  and  $B_c^{*+}(2S)$  are assumed to be negligible with respect to the measurement resolution, so that the production and decay vertices essentially overlap. Therefore, the daughter pions are required to be tracks used in the refitted PV (a procedure previously followed in Refs. [31, 32]). One of the pion candidates must have  $p_T > 0.8$  GeV and the other  $p_T > 0.6$  GeV. The  $B_c^+ \pi^+ \pi^-$  candidates must have  $|y| < 2.4$  and a vertex  $\chi^2$  probability larger than 10%. If several  $B_c^+ \pi^+ \pi^-$  candidates are found in the same event, only the one with the highest  $p_T$  is kept. Studies with simulated signal samples (providing  $S$ ) and measured sideband events (providing  $B$ ) have shown, through the  $S/\sqrt{S+B}$  figure of merit, that these are optimal event-selection criteria.

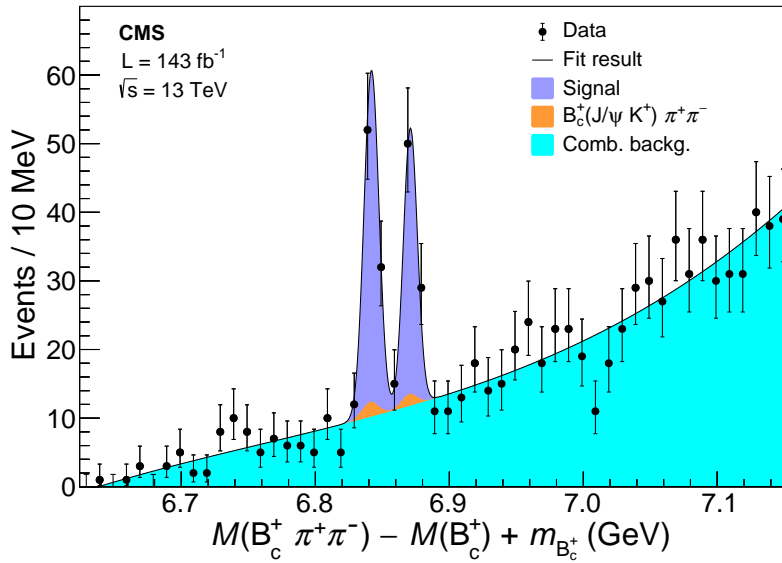

Figure 3: The  $M(B_c^+ \pi^+ \pi^-) - M(B_c^+) + m_{B_c^+}$  distribution. The  $B_c^+(2S)$  is assumed to be the right-most peak. The vertical bars on the points represent the statistical uncertainty in the data. The contributions from the various sources are shown by the stacked distributions. The solid line represents the result of the fit.

Figure 3 shows the  $M(B_c^+ \pi^+ \pi^-) - M(B_c^+) + m_{B_c^+}$  distribution, where  $M(B_c^+ \pi^+ \pi^-)$  and  $M(B_c^+)$  are, respectively, the reconstructed invariant masses of the  $B_c^+ \pi^+ \pi^-$  and  $B_c^+$  candidates, and  $m_{B_c^+}$  is the world-average  $B_c^+$  mass [25]. This variable is measured with a better resolution than  $M(B_c^+ \pi^+ \pi^-)$  and is, hence, advantageous when searching for peaks in the mass distribution. The measured distribution is fitted to a superposition of two Gaussian functions, representing the  $B_c^+(2S)$  and  $B_c^{*+}(2S)$  signal peaks, plus a third-order Chebyshev polynomial, modeling the continuum background, with all parameters left free in the fit. The two contributions arising from  $B_c^+ \rightarrow J/\psi K^+$  decays are also considered; they have shapes identical to the signal peaks, neglecting a shift to lower mass values that should be smaller than 1 MeV, and normalizations constrained by the ratio of the  $B_c^+ \rightarrow J/\psi K^+$  and  $B_c^+ \rightarrow J/\psi \pi^+$  signal yields, as previously mentioned. The unbinned extended maximum-likelihood fit gives  $67 \pm 10$  and  $51 \pm 10$  events for the lower-mass and higher-mass peak, respectively. Since these yields are not corrected for detection efficiencies and acceptances, they cannot be used to infer ratios of production cross sections. The two signals are well resolved, their mass difference being  $\Delta M = 29.1 \pm 1.5$  MeV, where the uncertainty is statistical only. The widths of the peaks are consistent with the value expected from simulation studies, which is approximately 6 MeV. The  $\chi^2$  between the binned distribution and the fit function is 42 for 39 degrees of freedom.

Studies of simulated samples show that the low-energy photon emitted in the  $B_c^{*+}(2S)$  decay has a very small reconstruction efficiency, of order 1%. Consequently, the photon is not detected and the mass of the  $B_c^{*+}(2S)$  cannot be measured. Given the predicted mass splittings mentioned before [11–13], the  $B_c^{*+}(2S)$  peak is expected to be observed at a mass lower than the  $B_c^+(2S)$ . The mass of the  $B_c^+(2S)$  meson, assumed to be the higher-mass peak in Fig. 3, is measured to be  $6871.0 \pm 1.2$  MeV, where the uncertainty is statistical only.

The  $M(B_c^+ \pi^+ \pi^-) - M(B_c^+) + m_{B_c^+}$  distribution has also been fitted with the two peaks modeled by a Breit–Wigner function, convolved with a Gaussian resolution function determined from the simulated samples. The result is that, for both peaks, the natural width parameter of the Breit–Wigner function is consistent with zero, indicating that both natural widths are small in comparison with the experimental resolution.

The fitting procedure was tested using randomly generated event samples, of sizes corresponding to the number of measured events, reflecting the nominal likelihood probability distribution functions and fitted parameters. No significant fit biases were found in the central values and uncertainties.

Several sources of systematic uncertainties have been considered. The mass measurements reported here are expected to be essentially insensitive to the event selection criteria. The analysis was repeated by splitting the data in exclusive sub-samples, depending on the  $B_c^+$  rapidity or  $p_T$ , or according to the data collection periods. The  $p_T$  thresholds were also varied, between 10 and 18 GeV for the  $B_c^+$  and between 3 and 5 GeV for the pion produced in the  $B_c^+$  decay. The results remain unchanged, hence no systematic uncertainty is assigned to the selection criteria. Also, no significant changes are seen in the results when the widths of the Gaussian functions used to describe the two peaks, or their ratio, are fixed to the values evaluated with the simulated event samples. The mass measurements might depend on the models used to describe the signal and background contributions. The impact of the fitting models has been evaluated by varying the considered functional forms. The combinatorial background, nominally represented by a third-order Chebyshev polynomial, has been alternatively modeled by the function  $(x - x_0)^\lambda \exp(\nu(x - x_0))$ , where  $\lambda$ ,  $\nu$ , and  $x_0$  are free parameters. For each of the two signal peaks, and corresponding  $B_c^+ \rightarrow J/\psi K^+$  terms, the default Gaussian function was replaced by a Breit–Wigner parametrization. The differences in the measured observables are taken as the systematic uncertainty associated with the fit modeling. While the alternative background model leads to a negligible change, the systematic uncertainties reflecting the modeling of the peaks are 0.8 and 0.7 MeV in the  $B_c^+(2S)$  mass and in  $\Delta M$ , respectively.

The nominal fit includes a  $B_c^+ \rightarrow J/\psi K^+$  component, with the same shape as the signal peaks and normalization defined by the expected ratio of the  $B_c^+ \rightarrow J/\psi K^+$  and  $B_c^+ \rightarrow J/\psi \pi^+$  yields in the  $B_c^+$  mass window, corrected by the ratio of the corresponding reconstruction efficiencies. The normalization has been increased by a factor of two, a variation ten times larger than the sum of the uncertainties in the ratio of branching fractions [25] and in the ratio of reconstruction efficiencies, and no significant effect has been seen on the results, so that no systematic uncertainty is associated with this background contribution. The  $B_c^+$  mass distribution includes a contribution from partially reconstructed decays. Their contamination in the  $M(B_c^+ \pi^+ \pi^-) - M(B_c^+) + m_{B_c^+}$  distribution is suppressed by the rejection of  $B_c^+$  candidates with invariant mass below 6.2 GeV. To evaluate possible resolution effects associated with this selection, the requirement was changed to 6.1 GeV, a variation that also leads to a larger contamination from  $B_c^+ \rightarrow J/\psi K^+$  events. The difference between the results, taking into account that the two event samples are strongly correlated, is not statistically significant, so that no systematic uncertainty is assigned. The potential bias introduced in the mass measurement by

possible misalignments of the tracker detectors has been evaluated through simulation studies and also by comparing distributions measured in the 2016 and 2017 running periods, a meaningful comparison given that an important fraction of the CMS tracker detector was replaced between these two years. The outcome is that the alignment of the detector leads to a negligible systematic uncertainty in the results of the present analysis. Thus, the total systematic uncertainties are 0.8 and 0.7 MeV, in the  $B_c^+(2S)$  mass measurement and in  $\Delta M$ , respectively.

The world-average  $B_c^+$  mass,  $m_{B_c^+} = 6274.9 \pm 0.8$  MeV [25], enters in the measurement of the  $B_c^+(2S)$  mass, thereby contributing an additional systematic uncertainty of 0.8 MeV. Strictly speaking, however, it is the mass difference  $M(B_c^+ \pi^+ \pi^-) - M(B_c^+)$  that is measured event by event, before adding the  $m_{B_c^+}$  constant, and it is convenient to report the  $B_c^+(2S)$  mass as  $M(B_c^+(2S)) - M(B_c^+) = 596.1 \pm 1.2$  (stat)  $\pm 0.8$  (syst) MeV, a value independent of  $m_{B_c^+}$ . Another interesting mass difference, also unaffected by the uncertainty in the  $B_c^+$  world-average mass, can be derived from the previously reported measurements:  $M(B_c^{*+}(2S)) - M(B_c^{*+}) = [M(B_c^+(2S)) - M(B_c^+)] - \Delta M = 567.0 \pm 1.0$  (total) MeV. Since the systematic effects previously mentioned cancel almost completely in this mass difference, the total uncertainty is dominated by the statistical term, which was determined by redoing the fit of the  $M(B_c^+ \pi^+ \pi^-) - M(B_c^+) + m_{B_c^+}$  distribution setting this new variable as a floating parameter, to properly account for the correlations between the parameters. The observation of two peaks, rather than one, is established with a significance of 6.5 standard deviations, evaluated with the likelihood-ratio technique confronting the two-peaks (ten free parameters) and one-peak (seven free parameters) hypotheses, using asymptotic formulae [33, 34] and accounting for the (dominant) systematic uncertainty in the signal model.

In summary, signals consistent with the  $B_c^+(2S)$  and  $B_c^{*+}(2S)$  states have been separately observed for the first time by investigating the  $B_c^+ \pi^+ \pi^-$  invariant mass spectrum measured by CMS. The analysis is based on the entire LHC sample of proton-proton collisions at a center-of-mass energy of 13 TeV, corresponding to a total integrated luminosity of  $143 \text{ fb}^{-1}$ . The two peaks are well resolved, with a measured mass difference of  $\Delta M = 29.1 \pm 1.5$  (stat)  $\pm 0.7$  (syst) MeV. The  $B_c^+(2S)$  mass is measured to be  $6871.0 \pm 1.2$  (stat)  $\pm 0.8$  (syst)  $\pm 0.8$  ( $B_c^+$ ) MeV, where the last term is the uncertainty in the world-average  $B_c^+$  mass. Because the low-energy photon emitted in the  $B_c^{*+} \rightarrow B_c^+ \gamma$  radiative decay is not reconstructed, the observed  $B_c^{*+}(2S)$  peak has a mass lower than the true value, which remains unknown. These measurements contribute significantly to the detailed characterization of heavy meson spectroscopy and provide a rich source of information on the nonperturbative QCD processes that bind heavy quarks into hadrons.

## Acknowledgments

We congratulate our colleagues in the CERN accelerator departments for the excellent performance of the LHC and thank the technical and administrative staffs at CERN and at other CMS institutes for their contributions to the success of the CMS effort. In addition, we gratefully acknowledge the computing centers and personnel of the Worldwide LHC Computing Grid for delivering so effectively the computing infrastructure essential to our analyses. Finally, we acknowledge the enduring support for the construction and operation of the LHC and the CMS detector provided by the following funding agencies: BMBWF and FWF (Austria); FNRS and FWO (Belgium); CNPq, CAPES, FAPERJ, FAPERGS, and FAPESP (Brazil); MES (Bulgaria); CERN; CAS, MoST, and NSFC (China); COLCIENCIAS (Colombia); MSES and CSF (Croatia); RPF (Cyprus); SENESCYT (Ecuador); MoER, ERC IUT, and ERDF (Estonia); Academy of Finland, MEC, and HIP (Finland); CEA and CNRS/IN2P3 (France); BMBF, DFG, and HGF



(Germany); GSRT (Greece); NKFIA (Hungary); DAE and DST (India); IPM (Iran); SFI (Ireland); INFN (Italy); MSIP and NRF (Republic of Korea); MES (Latvia); LAS (Lithuania); MOE and UM (Malaysia); BUAP, CINVESTAV, CONACYT, LNS, SEP, and UASLP-FAI (Mexico); MOS (Montenegro); MBIE (New Zealand); PAEC (Pakistan); MSHE and NSC (Poland); FCT (Portugal); JINR (Dubna); MON, RosAtom, RAS, RFBR, and NRC KI (Russia); MESTD (Serbia); SEIDI, CPAN, PCTI, and FEDER (Spain); MOSTR (Sri Lanka); Swiss Funding Agencies (Switzerland); MST (Taipei); ThEPCenter, IPST, STAR, and NSTDA (Thailand); TUBITAK and TAEK (Turkey); NASU and SFFR (Ukraine); STFC (United Kingdom); DOE and NSF (USA).

## References

- [1] CDF Collaboration, "Observation of the  $B_c$  meson in  $p\bar{p}$  collisions at  $\sqrt{s} = 1.8$  TeV", *Phys. Rev. Lett.* **81** (1998) 2432, doi:10.1103/PhysRevLett.81.2432, arXiv:hep-ex/9805034.
- [2] E. J. Eichten and C. Quigg, "Mesons with beauty and charm: Spectroscopy", *Phys. Rev. D* **49** (1994) 5845, doi:10.1103/PhysRevD.49.5845, arXiv:hep-ph/9402210.
- [3] S. S. Gershtein, V. V. Kiselev, A. K. Likhoded, and A. V. Tkabladze, " $B_c$  spectroscopy", *Phys. Rev. D* **51** (1995) 3613, doi:10.1103/PhysRevD.51.3613, arXiv:hep-ph/9406339.
- [4] J. Zeng, J. W. Van Orden, and W. Roberts, "Heavy mesons in a relativistic model", *Phys. Rev. D* **52** (1995) 5229, doi:10.1103/PhysRevD.52.5229, arXiv:hep-ph/9412269.
- [5] S. N. Gupta and J. M. Johnson, " $B_c$  spectroscopy in a quantum chromodynamic potential model", *Phys. Rev. D* **53** (1996) 312, doi:10.1103/PhysRevD.53.312, arXiv:hep-ph/9511267.
- [6] C. T. H. Davies et al., " $B_c$  spectroscopy from lattice QCD", *Phys. Lett. B* **382** (1996) 131, doi:10.1016/0370-2693(96)00650-8, arXiv:hep-lat/9602020.
- [7] L. P. Fulcher, "Phenomenological predictions of the properties of the  $B_c$  system", *Phys. Rev. D* **60** (1999) 074006, doi:10.1103/PhysRevD.60.074006, arXiv:hep-ph/9806444.
- [8] D. Ebert, R. N. Faustov, and V. O. Galkin, "Properties of heavy quarkonia and  $B_c$  mesons in the relativistic quark model", *Phys. Rev. D* **67** (2003) 014027, doi:10.1103/PhysRevD.67.014027, arXiv:hep-ph/0210381.
- [9] S. Godfrey, "Spectroscopy of  $B_c$  mesons in the relativized quark model", *Phys. Rev. D* **70** (2004) 054017, doi:10.1103/PhysRevD.70.054017, arXiv:hep-ph/0406228.
- [10] A. Berezhnoy and A. Likhoded, "The observation possibility of  $B_c$  excitations at LHC", *PoS QFTHEP2013* (2013) 051, doi:10.22323/1.183.0051, arXiv:1307.5993.
- [11] E. B. Gregory et al., "A prediction of the  $B_c^*$  mass in full lattice QCD", *Phys. Rev. Lett.* **104** (2010) 022001, doi:10.1103/PhysRevLett.104.022001, arXiv:0909.4462.
- [12] R. J. Dowdall, C. T. H. Davies, T. C. Hammant, and R. R. Horgan, "Precise heavy-light meson masses and hyperfine splittings from lattice QCD including charm quarks in the sea", *Phys. Rev. D* **86** (2012) 094510, doi:10.1103/PhysRevD.86.094510, arXiv:1207.5149.

- 
- [13] N. Mathur, M. Padmanath, and S. Mondal, “Precise predictions of charmed-bottom hadrons from lattice QCD”, *Phys. Rev. Lett.* **121** (2018) 202002, doi:10.1103/PhysRevLett.121.202002, arXiv:1806.04151.
- [14] ATLAS Collaboration, “Observation of an excited  $B_c^\pm$  meson state with the ATLAS detector”, *Phys. Rev. Lett.* **113** (2014) 212004, doi:10.1103/PhysRevLett.113.212004, arXiv:1407.1032.
- [15] LHCb Collaboration, “Search for excited  $B_c^+$  states”, *JHEP* **01** (2018) 138, doi:10.1007/JHEP01(2018)138, arXiv:1712.04094.
- [16] CMS Collaboration, “The CMS experiment at the CERN LHC”, *JINST* **3** (2008) S08004, doi:10.1088/1748-0221/3/08/S08004.
- [17] CMS Collaboration, “The CMS trigger system”, *JINST* **12** (2017) P01020, doi:10.1088/1748-0221/12/01/P01020, arXiv:1609.02366.
- [18] CMS Collaboration, “Performance of the CMS muon detector and muon reconstruction with proton-proton collisions at  $\sqrt{s} = 13$  TeV”, *JINST* **13** (2018) P06015, doi:10.1088/1748-0221/13/06/P06015, arXiv:1804.04528.
- [19] C.-H. Chang, X.-Y. Wang, and X.-G. Wu, “BCVEGPY2.2: A newly upgraded version for hadronic production of the meson  $B_c$  and its excited states”, *Comput. Phys. Commun.* **197** (2015) 335, doi:10.1016/j.cpc.2015.07.015, arXiv:1507.05176.
- [20] T. Sjöstrand, S. Mrenna, and P. Skands, “A brief introduction to PYTHIA 8.1”, *Comp. Phys. Comm.* **178** (2008) 852, doi:10.1016/j.cpc.2008.01.036, arXiv:0710.3820.
- [21] D. J. Lange, “The EvtGen particle decay simulation package”, *Nucl. Instrum. Meth. A* **462** (2001) 152, doi:10.1016/S0168-9002(01)00089-4.
- [22] E. Barberio and Z. Was, “PHOTOS - a universal Monte Carlo for QED radiative corrections: version 2.0”, *Comput. Phys. Commun.* **79** (1994) 291, doi:10.1016/0010-4655(94)90074-4.
- [23] GEANT4 Collaboration, “GEANT4—a simulation toolkit”, *Nucl. Instrum. Meth. A* **506** (2003) 250, doi:10.1016/S0168-9002(03)01368-8.
- [24] CMS Collaboration, “Description and performance of track and primary-vertex reconstruction with the CMS tracker”, *JINST* **9** (2014) P10009, doi:10.1088/1748-0221/9/10/P10009, arXiv:1405.6569.
- [25] Particle Data Group, M. Tanabashi et al., “Review of Particle Physics”, *Phys. Rev. D* **98** (2018) 030001, doi:10.1103/PhysRevD.98.030001.
- [26] R. Frühwirth, W. Waltenberger, and P. Vanlaer, “Adaptive vertex fitting”, *J. Phys. G* **34** (2007) N343, doi:10.1088/0954-3899/34/12/N01.
- [27] CMS Collaboration, “Measurement of the ratio of the production cross sections times branching fractions of  $B_c^\pm \rightarrow J/\psi \pi^\pm$  and  $B^\pm \rightarrow J/\psi K^\pm$  and  $\mathcal{B}(B_c^\pm \rightarrow J/\psi \pi^\pm \pi^\pm \pi^\mp) / \mathcal{B}(B_c^\pm \rightarrow J/\psi \pi^\pm)$  in pp collisions at  $\sqrt{s} = 7$  TeV”, *JHEP* **01** (2015) 063, doi:10.1007/JHEP01(2015)063, arXiv:1410.5729.

- [28] CMS Collaboration, “Measurement of b hadron lifetimes in pp collisions at  $\sqrt{s} = 8 \text{ TeV}$ ”, *Eur. Phys. J. C* **78** (2018) 457, doi:10.1140/epjc/s10052-018-5929-3, arXiv:1710.08949. [Erratum: doi:10.1140/epjc/s10052-018-6014-7].
- [29] ARGUS Collaboration, “Search for hadronic  $b \rightarrow u$  decays”, *Phys. Lett. B* **241** (1990) 278, doi:10.1016/0370-2693(90)91293-K.
- [30] LHCb Collaboration, “Measurement of the ratio of branching fractions  $\mathcal{B}(B_c^+ \rightarrow J/\psi K^+)/\mathcal{B}(B_c^+ \rightarrow J/\psi \pi^+)$ ”, *JHEP* **09** (2016) 153, doi:10.1007/JHEP09(2016)153, arXiv:1607.06823.
- [31] CMS Collaboration, “Search for the X(5568) state decaying into  $B_s^0 \pi^\pm$  in proton-proton collisions at  $\sqrt{s} = 8 \text{ TeV}$ ”, *Phys. Rev. Lett.* **120** (2018) 202005, doi:10.1103/PhysRevLett.120.202005, arXiv:1712.06144.
- [32] CMS Collaboration, “Studies of  $B_{s2}^*(5840)^0$  and  $B_{s1}(5830)^0$  mesons including the observation of the  $B_{s2}^*(5840)^0 \rightarrow B^0 K_S^0$  decay in proton-proton collisions at  $\sqrt{s} = 8 \text{ TeV}$ ”, *Eur. Phys. J. C* **78** (2018) 939, doi:10.1140/epjc/s10052-018-6390-z, arXiv:1809.03578.
- [33] S. S. Wilks, “The large-sample distribution of the likelihood ratio for testing composite hypotheses”, *Annals Math. Statist.* **9** (1938) 60, doi:10.1214/aoms/1177732360.
- [34] G. Cowan, K. Cranmer, E. Gross, and O. Vitells, “Asymptotic formulae for likelihood-based tests of new physics”, *Eur. Phys. J. C* **71** (2011) 1554, doi:10.1140/epjc/s10052-011-1554-0, arXiv:1007.1727. [Erratum: doi:10.1140/epjc/s10052-013-2501-z].



## A The CMS Collaboration

### Yerevan Physics Institute, Yerevan, Armenia

A.M. Sirunyan<sup>†</sup>, A. Tumasyan

### Institut für Hochenergiephysik, Wien, Austria

W. Adam, F. Ambrogio, T. Bergauer, J. Brandstetter, M. Dragicevic, J. Erö, A. Escalante Del Valle, M. Flechl, R. Frühwirth<sup>1</sup>, M. Jeitler<sup>1</sup>, N. Krammer, I. Krätschmer, D. Liko, T. Madlener, I. Mikulec, N. Rad, J. Schieck<sup>1</sup>, R. Schöfbeck, M. Spanring, D. Spitzbart, W. Waltenberger, J. Wittmann, C.-E. Wulz<sup>1</sup>, M. Zarucki

### Institute for Nuclear Problems, Minsk, Belarus

V. Drugakov, V. Mossolov, J. Suarez Gonzalez

### Universiteit Antwerpen, Antwerpen, Belgium

M.R. Darwish, E.A. De Wolf, D. Di Croce, X. Janssen, J. Lauwers, A. Lelek, M. Pieters, H. Van Haevermaet, P. Van Mechelen, N. Van Remortel

### Vrije Universiteit Brussel, Brussel, Belgium

F. Blekman, E.S. Bols, S.S. Chhibra, J. D'Hondt, J. De Clercq, G. Flouris, D. Lontkovskyi, S. Lowette, I. Marchesini, S. Moortgat, L. Moreels, Q. Python, K. Skovpen, S. Tavernier, W. Van Doninck, P. Van Mulders, I. Van Parijs

### Université Libre de Bruxelles, Bruxelles, Belgium

D. Beghin, B. Bilin, H. Brun, B. Clerbaux, G. De Lentdecker, H. Delannoy, B. Dorney, L. Favart, A. Grebenyuk, A.K. Kalsi, J. Luetic, A. Popov, N. Postiau, E. Starling, L. Thomas, C. Vander Velde, P. Vanlaer, D. Vannerom, Q. Wang

### Ghent University, Ghent, Belgium

T. Cornelis, D. Dobur, A. Fagot, M. Gul, I. Khvastunov<sup>2</sup>, C. Roskas, D. Trocino, M. Tytgat, W. Verbeke, B. Vermassen, M. Vit, N. Zaganidis

### Université Catholique de Louvain, Louvain-la-Neuve, Belgium

O. Bondu, G. Bruno, C. Caputo, P. David, C. Delaere, M. Delcourt, A. Giammanco, G. Krintiras, V. Lemaitre, A. Magitteri, K. Piotrkowski, J. Prisciandaro, A. Saggio, M. Vidal Marono, P. Vischia, J. Zobec

### Centro Brasileiro de Pesquisas Fisicas, Rio de Janeiro, Brazil

F.L. Alves, G.A. Alves, G. Correia Silva, C. Hensel, A. Moraes, P. Rebello Teles

### Universidade do Estado do Rio de Janeiro, Rio de Janeiro, Brazil

E. Belchior Batista Das Chagas, W. Carvalho, J. Chinellato<sup>3</sup>, E. Coelho, E.M. Da Costa, G.G. Da Silveira<sup>4</sup>, D. De Jesus Damiao, S. Fonseca De Souza, L.M. Huertas Guativa, H. Malbouisson, D. Matos Figueiredo, M. Medina Jaime<sup>5</sup>, M. Melo De Almeida, C. Mora Herrera, L. Mundim, H. Nogima, L.J. Sanchez Rosas, A. Santoro, A. Sznajder, M. Thiel, E.J. Tonelli Manganote<sup>3</sup>, F. Torres Da Silva De Araujo, A. Vilela Pereira

### Universidade Estadual Paulista <sup>a</sup>, Universidade Federal do ABC <sup>b</sup>, São Paulo, Brazil

S. Ahuja<sup>a</sup>, C.A. Bernardes<sup>a</sup>, L. Calligaris<sup>a</sup>, D. De Souza Lemos, T.R. Fernandez Perez Tomei<sup>a</sup>, E.M. Gregores<sup>b</sup>, P.G. Mercadante<sup>b</sup>, S.F. Novaes<sup>a</sup>, SandraS. Padula<sup>a</sup>

### Institute for Nuclear Research and Nuclear Energy, Bulgarian Academy of Sciences, Sofia, Bulgaria

A. Aleksandrov, R. Hadjiiska, P. Iaydjiev, A. Marinov, M. Misheva, M. Rodozov, M. Shopova, G. Sultanov

**University of Sofia, Sofia, Bulgaria**

A. Dimitrov, L. Litov, B. Pavlov, P. Petkov

**Beihang University, Beijing, China**

W. Fang<sup>6</sup>, X. Gao<sup>6</sup>, L. Yuan

**Institute of High Energy Physics, Beijing, China**

M. Ahmad, G.M. Chen, H.S. Chen, M. Chen, C.H. Jiang, D. Leggat, H. Liao, Z. Liu, S.M. Shaheen<sup>7</sup>, A. Spiezia, J. Tao, E. Yazgan, H. Zhang, S. Zhang<sup>7</sup>, J. Zhao

**State Key Laboratory of Nuclear Physics and Technology, Peking University, Beijing, China**

Y. Ban, G. Chen, J. Li, L. Li, Q. Li, Y. Mao, S.J. Qian, D. Wang

**Tsinghua University, Beijing, China**

Y. Wang

**Universidad de Los Andes, Bogota, Colombia**

C. Avila, A. Cabrera, L.F. Chaparro Sierra, C. Florez, C.F. González Hernández, M.A. Segura Delgado

**Universidad de Antioquia, Medellin, Colombia**

J. Mejia Guisao, J.D. Ruiz Alvarez

**University of Split, Faculty of Electrical Engineering, Mechanical Engineering and Naval Architecture, Split, Croatia**

D. Giljanović, N. Godinovic, D. Lelas, I. Puljak, T. Sculac

**University of Split, Faculty of Science, Split, Croatia**

Z. Antunovic, M. Kovac

**Institute Rudjer Boskovic, Zagreb, Croatia**

V. Brigljevic, D. Ferencek, K. Kadija, B. Mesic, M. Roguljic, A. Starodumov<sup>8</sup>, T. Susa

**University of Cyprus, Nicosia, Cyprus**

M.W. Ather, A. Attikis, E. Erodotou, A. Ioannou, M. Kolosova, S. Konstantinou, G. Mavromanolakis, J. Mousa, C. Nicolaou, F. Ptochos, P.A. Razis, H. Rykaczewski, D. Tsiakkouri

**Charles University, Prague, Czech Republic**

M. Finger<sup>9</sup>, M. Finger Jr.<sup>9</sup>

**Escuela Politecnica Nacional, Quito, Ecuador**

E. Ayala

**Universidad San Francisco de Quito, Quito, Ecuador**

E. Carrera Jarrin

**Academy of Scientific Research and Technology of the Arab Republic of Egypt, Egyptian Network of High Energy Physics, Cairo, Egypt**

Y. Assran<sup>10,11</sup>, S. Elgammal<sup>11</sup>

**National Institute of Chemical Physics and Biophysics, Tallinn, Estonia**

S. Bhowmik, A. Carvalho Antunes De Oliveira, R.K. Dewanjee, K. Ehataht, M. Kadastik, M. Raidal, C. Veelken

**Department of Physics, University of Helsinki, Helsinki, Finland**

P. Eerola, H. Kirschenmann, J. Pekkanen, M. Voutilainen

**Helsinki Institute of Physics, Helsinki, Finland**

J. Havukainen, J.K. Heikkilä, T. Järvinen, V. Karimäki, R. Kinnunen, T. Lampén, K. Lassila-Perini, S. Laurila, S. Lehti, T. Lindén, P. Luukka, T. Mäenpää, H. Siikonen, E. Tuominen, J. Tuominiemi

**Lappeenranta University of Technology, Lappeenranta, Finland**

T. Tuuva

**IRFU, CEA, Université Paris-Saclay, Gif-sur-Yvette, France**

M. Besancon, F. Couderc, M. Dejardin, D. Denegri, B. Fabbro, J.L. Faure, F. Ferri, S. Ganjour, A. Givernaud, P. Gras, G. Hamel de Monchenault, P. Jarry, C. Leloup, E. Locci, J. Malcles, J. Rander, A. Rosowsky, M.Ö. Sahin, A. Savoy-Navarro<sup>12</sup>, M. Titov

**Laboratoire Leprince-Ringuet, Ecole polytechnique, CNRS/IN2P3, Université Paris-Saclay, Palaiseau, France**

C. Amendola, F. Beaudette, P. Busson, C. Charlot, B. Diab, R. Granier de Cassagnac, I. Kucher, A. Lobanov, C. Martin Perez, M. Nguyen, C. Ochando, P. Paganini, J. Rembser, R. Salerno, J.B. Sauvan, Y. Sirois, A. Zabi, A. Zghiche

**Université de Strasbourg, CNRS, IPHC UMR 7178, Strasbourg, France**

J.-L. Agram<sup>13</sup>, J. Andrea, D. Bloch, G. Bourgatte, J.-M. Brom, E.C. Chabert, C. Collard, E. Conte<sup>13</sup>, J.-C. Fontaine<sup>13</sup>, D. Gelé, U. Goerlach, M. Jansová, A.-C. Le Bihan, N. Tonon, P. Van Hove

**Centre de Calcul de l'Institut National de Physique Nucleaire et de Physique des Particules, CNRS/IN2P3, Villeurbanne, France**

S. Gadrat

**Université de Lyon, Université Claude Bernard Lyon 1, CNRS-IN2P3, Institut de Physique Nucléaire de Lyon, Villeurbanne, France**

S. Beauceron, C. Bernet, G. Boudoul, C. Camen, N. Chanon, R. Chierici, D. Contardo, P. Depasse, H. El Mamouni, J. Fay, S. Gascon, M. Gouzevitch, B. Ille, F. Lagarde, I.B. Laktineh, H. Lattaud, M. Lethuillier, L. Mirabito, S. Perries, V. Sordini, G. Touquet, M. Vander Donckt, S. Viret

**Georgian Technical University, Tbilisi, Georgia**

T. Toriashvili<sup>14</sup>

**Tbilisi State University, Tbilisi, Georgia**

Z. Tsamalaidze<sup>9</sup>

**RWTH Aachen University, I. Physikalisches Institut, Aachen, Germany**

C. Autermann, L. Feld, M.K. Kiesel, K. Klein, M. Lipinski, D. Meuser, A. Pauls, M. Preuten, M.P. Rauch, C. Schomakers, M. Teroerde, B. Wittmer

**RWTH Aachen University, III. Physikalisches Institut A, Aachen, Germany**

A. Albert, M. Erdmann, S. Erdweg, T. Esch, B. Fischer, R. Fischer, S. Ghosh, T. Hebbeker, K. Hoepfner, H. Keller, L. Mastrolorenzo, M. Merschmeyer, A. Meyer, P. Millet, G. Mocellin, S. Mondal, S. Mukherjee, D. Noll, A. Novak, T. Pook, A. Pozdnyakov, T. Quast, M. Radziej, Y. Rath, H. Reithler, M. Rieger, A. Schmidt, S.C. Schuler, A. Sharma, S. Thüer, S. Wiedenbeck

**RWTH Aachen University, III. Physikalisches Institut B, Aachen, Germany**

G. Flügge, O. Hlushchenko, T. Kress, T. Müller, A. Nehr Korn, A. Nowack, C. Pistone, O. Pooth, D. Roy, H. Sert, A. Stahl<sup>15</sup>

**Deutsches Elektronen-Synchrotron, Hamburg, Germany**

M. Aldaya Martin, C. Asawatangtrakuldee, P. Asmuss, I. Babounikau, H. Bakhshiansohi, K. Beernaert, O. Behnke, U. Behrens, A. Bermúdez Martínez, D. Bertsche, A.A. Bin Anuar, K. Borras<sup>16</sup>, V. Botta, A. Campbell, A. Cardini, P. Connor, S. Consuegra Rodríguez, C. Contreras-Campana, V. Danilov, A. De Wit, M.M. Defranchis, C. Diez Pardos, D. Domínguez Damiani, G. Eckerlin, D. Eckstein, T. Eichhorn, A. Elwood, E. Eren, E. Gallo<sup>17</sup>, A. Geiser, J.M. Grados Luyando, A. Grohsjean, M. Guthoff, M. Haranko, A. Harb, N.Z. Jomhari, H. Jung, A. Kasem<sup>16</sup>, M. Kasemann, J. Keaveney, C. Kleinwort, J. Knolle, D. Krücker, T. Lenz, J. Leonard, J. Lidrych, K. Lipka, W. Lohmann<sup>18</sup>, R. Mankel, I.-A. Melzer-Pellmann, A.B. Meyer, M. Meyer, M. Missiroli, G. Mittag, J. Mnich, A. Mussgiller, V. Myronenko, D. Pérez Adán, S.K. Pflitsch, D. Pitzl, A. Raspereza, A. Saibel, M. Savitskyi, V. Scheurer, P. Schütze, C. Schwanenberger, R. Shevchenko, A. Singh, H. Tholen, O. Turkot, A. Vagnerini, M. Van De Klundert, G.P. Van Onsem, R. Walsh, Y. Wen, K. Wichmann, C. Wissing, O. Zenaiev, R. Zlebcik

**University of Hamburg, Hamburg, Germany**

R. Aggleton, S. Bein, L. Benato, A. Benecke, V. Blobel, T. Dreyer, A. Ebrahimi, A. Fröhlich, C. Garbers, E. Garutti, D. Gonzalez, P. Gunnellini, J. Haller, A. Hinzmann, A. Karavdina, G. Kasieczka, R. Klanner, R. Kogler, N. Kovalchuk, S. Kurz, V. Kutzner, J. Lange, T. Lange, A. Malara, D. Marconi, J. Multhaupt, M. Niedziela, C.E.N. Niemeyer, D. Nowatschin, A. Perieanu, A. Reimers, O. Rieger, C. Scharf, P. Schleper, S. Schumann, J. Schwandt, J. Sonneveld, H. Stadie, G. Steinbrück, F.M. Stober, M. Stöver, B. Vormwald, I. Zoi

**Karlsruher Institut fuer Technologie, Karlsruhe, Germany**

M. Akbiyik, C. Barth, M. Baselga, S. Baur, T. Berger, E. Butz, T. Chwalek, W. De Boer, A. Dierlamm, K. El Morabit, M. Giffels, P. Goldenzweig, M.A. Harrendorf, F. Hartmann<sup>15</sup>, U. Husemann, S. Kudella, S. Mitra, M.U. Mozer, Th. Müller, M. Musich, A. Nürnberg, G. Quast, K. Rabbertz, M. Schröder, I. Shvetsov, H.J. Simonis, R. Ulrich, M. Weber, C. Wöhrmann, R. Wolf

**Institute of Nuclear and Particle Physics (INPP), NCSR Demokritos, Aghia Paraskevi, Greece**

G. Anagnostou, P. Asenov, G. Daskalakis, T. Geralis, A. Kyriakis, D. Loukas, G. Paspalaki

**National and Kapodistrian University of Athens, Athens, Greece**

M. Diamantopoulou, G. Karathanasis, P. Kontaxakis, A. Panagiotou, I. Papavergou, N. Saoulidou, K. Theofilatos, K. Vellidis

**National Technical University of Athens, Athens, Greece**

G. Bakas, K. Kousouris, I. Papakrivopoulos, G. Tsipolitis

**University of Ioánnina, Ioánnina, Greece**

I. Evangelou, C. Foudas, P. Giannelis, P. Katsoulis, P. Kokkas, S. Mallios, K. Manitará, N. Manthos, I. Papadopoulos, E. Paradas, J. Strologas, F.A. Triantis, D. Tsitsonis

**MTA-ELTE Lendület CMS Particle and Nuclear Physics Group, Eötvös Loránd University, Budapest, Hungary**

M. Bartók<sup>19</sup>, M. Csanad, P. Major, K. Mandal, A. Mehta, M.I. Nagy, G. Pasztor, O. Surányi, G.I. Veres

**Wigner Research Centre for Physics, Budapest, Hungary**

G. Bencze, C. Hajdu, D. Horvath<sup>20</sup>, Á. Hunyadi, F. Sikler, T.Á. Vámi, V. Veszpremi, G. Vesztergombi<sup>†</sup>



**Institute of Nuclear Research ATOMKI, Debrecen, Hungary**

N. Beni, S. Czellar, J. Karancsi<sup>19</sup>, A. Makovec, J. Molnar, Z. Szillasi

**Institute of Physics, University of Debrecen, Debrecen, Hungary**

P. Raics, D. Teyssier, Z.L. Trocsanyi, B. Ujvari

**Indian Institute of Science (IISc), Bangalore, India**

S. Choudhury, J.R. Komaragiri, P.C. Tiwari

**National Institute of Science Education and Research, HBNI, Bhubaneswar, India**

S. Bahinipati<sup>22</sup>, C. Kar, P. Mal, V.K. Muraleedharan Nair Bindhu, A. Nayak<sup>23</sup>, S. Roy Chowdhury, D.K. Sahoo<sup>22</sup>, S.K. Swain

**Panjab University, Chandigarh, India**

S. Bansal, V. Bhatnagar, S. Chauhan, R. Chawla, N. Dhingra, R. Gupta, A. Kaur, M. Kaur, S. Kaur, P. Kumari, M. Lohan, M. Meena, K. Sandeep, S. Sharma, J.B. Singh, A.K. Viridi, G. Walia

**University of Delhi, Delhi, India**

A. Bhardwaj, B.C. Choudhary, R.B. Garg, M. Gola, S. Keshri, Ashok Kumar, S. Malhotra, M. Naimuddin, P. Priyanka, K. Ranjan, Aashaq Shah, R. Sharma

**Saha Institute of Nuclear Physics, HBNI, Kolkata, India**

R. Bhardwaj<sup>24</sup>, M. Bharti<sup>24</sup>, R. Bhattacharya, S. Bhattacharya, U. Bhawandeep<sup>24</sup>, D. Bhowmik, S. Dey, S. Dutta, S. Ghosh, M. Maity<sup>25</sup>, K. Mondal, S. Nandan, A. Purohit, P.K. Rout, A. Roy, G. Saha, S. Sarkar, T. Sarkar<sup>25</sup>, M. Sharan, B. Singh<sup>24</sup>, S. Thakur<sup>24</sup>

**Indian Institute of Technology Madras, Madras, India**

P.K. Behera, A. Muhammad

**Bhabha Atomic Research Centre, Mumbai, India**

R. Chudasama, D. Dutta, V. Jha, V. Kumar, D.K. Mishra, P.K. Netrakanti, L.M. Pant, P. Shukla

**Tata Institute of Fundamental Research-A, Mumbai, India**

T. Aziz, M.A. Bhat, S. Dugad, G.B. Mohanty, N. Sur, RavindraKumar Verma

**Tata Institute of Fundamental Research-B, Mumbai, India**

S. Banerjee, S. Bhattacharya, S. Chatterjee, P. Das, M. Guchait, S. Karmakar, S. Kumar, G. Majumder, K. Mazumdar, S. Sawant

**Indian Institute of Science Education and Research (IISER), Pune, India**

S. Chauhan, S. Dube, V. Hegde, A. Kapoor, K. Kothekar, S. Pandey, A. Rane, A. Rastogi, S. Sharma

**Institute for Research in Fundamental Sciences (IPM), Tehran, Iran**

S. Chenarani<sup>26</sup>, E. Eskandari Tadavani, S.M. Etesami<sup>26</sup>, M. Khakzad, M. Mohammadi Najafabadi, M. Naseri, F. Rezaei Hosseinabadi, B. Safarzadeh<sup>27</sup>

**University College Dublin, Dublin, Ireland**

M. Felcini, M. Grunewald

**INFN Sezione di Bari <sup>a</sup>, Università di Bari <sup>b</sup>, Politecnico di Bari <sup>c</sup>, Bari, Italy**

M. Abbrescia<sup>a,b</sup>, C. Calabria<sup>a,b</sup>, A. Colaleo<sup>a</sup>, D. Creanza<sup>a,c</sup>, L. Cristella<sup>a,b</sup>, N. De Filippis<sup>a,c</sup>, M. De Palma<sup>a,b</sup>, A. Di Florio<sup>a,b</sup>, L. Fiore<sup>a</sup>, A. Gelmi<sup>a,b</sup>, G. Iaselli<sup>a,c</sup>, M. Ince<sup>a,b</sup>, S. Lezki<sup>a,b</sup>, G. Maggi<sup>a,c</sup>, M. Maggi<sup>a</sup>, G. Miniello<sup>a,b</sup>, S. My<sup>a,b</sup>, S. Nuzzo<sup>a,b</sup>, A. Pompili<sup>a,b</sup>, G. Pugliese<sup>a,c</sup>, A. Ranieri<sup>a</sup>, G. Selvaggi<sup>a,b</sup>, L. Silvestris<sup>a</sup>, R. Venditti<sup>a</sup>, P. Verwilligen<sup>a</sup>

**INFN Sezione di Bologna <sup>a</sup>, Università di Bologna <sup>b</sup>, Bologna, Italy**

G. Abbiendi<sup>a</sup>, C. Battilana<sup>a,b</sup>, D. Bonacorsi<sup>a,b</sup>, L. Borgonovi<sup>a,b</sup>, S. Braibant-Giacomelli<sup>a,b</sup>, R. Campanini<sup>a,b</sup>, P. Capiluppi<sup>a,b</sup>, A. Castro<sup>a,b</sup>, F.R. Cavallo<sup>a</sup>, C. Ciocca<sup>a</sup>, M. Cuffiani<sup>a,b</sup>, G.M. Dallavalle<sup>a</sup>, F. Fabbri<sup>a</sup>, A. Fanfani<sup>a,b</sup>, E. Fontanesi, P. Giacomelli<sup>a</sup>, C. Grandi<sup>a</sup>, L. Guiducci<sup>a,b</sup>, F. Iemmi<sup>a,b</sup>, S. Lo Meo<sup>a,28</sup>, S. Marcellini<sup>a</sup>, G. Masetti<sup>a</sup>, F.L. Navarra<sup>a,b</sup>, A. Perrotta<sup>a</sup>, F. Primavera<sup>a,b</sup>, A.M. Rossi<sup>a,b</sup>, T. Rovelli<sup>a,b</sup>, G.P. Siroli<sup>a,b</sup>, N. Tosi<sup>a</sup>

**INFN Sezione di Catania <sup>a</sup>, Università di Catania <sup>b</sup>, Catania, Italy**

S. Albergo<sup>a,b,29</sup>, S. Costa<sup>a,b</sup>, A. Di Mattia<sup>a</sup>, R. Potenza<sup>a,b</sup>, A. Tricomi<sup>a,b,29</sup>, C. Tuve<sup>a,b</sup>

**INFN Sezione di Firenze <sup>a</sup>, Università di Firenze <sup>b</sup>, Firenze, Italy**

G. Barbagli<sup>a</sup>, R. Ceccarelli, K. Chatterjee<sup>a,b</sup>, V. Ciulli<sup>a,b</sup>, C. Civinini<sup>a</sup>, R. D'Alessandro<sup>a,b</sup>, E. Focardi<sup>a,b</sup>, G. Latino, P. Lenzi<sup>a,b</sup>, M. Meschini<sup>a</sup>, S. Paoletti<sup>a</sup>, L. Russo<sup>a,30</sup>, G. Sguazzoni<sup>a</sup>, D. Strom<sup>a</sup>, L. Viliani<sup>a</sup>

**INFN Laboratori Nazionali di Frascati, Frascati, Italy**

L. Benussi, S. Bianco, F. Fabbri, D. Piccolo

**INFN Sezione di Genova <sup>a</sup>, Università di Genova <sup>b</sup>, Genova, Italy**

F. Ferro<sup>a</sup>, R. Mulargia<sup>a,b</sup>, E. Robutti<sup>a</sup>, S. Tosi<sup>a,b</sup>

**INFN Sezione di Milano-Bicocca <sup>a</sup>, Università di Milano-Bicocca <sup>b</sup>, Milano, Italy**

A. Benaglia<sup>a</sup>, A. Beschi<sup>a,b</sup>, F. Brivio<sup>a,b</sup>, V. Ciriolo<sup>a,b,15</sup>, S. Di Guida<sup>a,b,15</sup>, M.E. Dinardo<sup>a,b</sup>, P. Dini<sup>a</sup>, S. Fiorendi<sup>a,b</sup>, S. Gennai<sup>a</sup>, A. Ghezzi<sup>a,b</sup>, P. Govoni<sup>a,b</sup>, M. Malberti<sup>a</sup>, S. Malvezzi<sup>a</sup>, D. Menasce<sup>a</sup>, F. Monti<sup>a,b</sup>, L. Moroni<sup>a</sup>, G. Ortona<sup>a,b</sup>, M. Paganoni<sup>a,b</sup>, D. Pedrini<sup>a</sup>, S. Ragazzi<sup>a,b</sup>, T. Tabarelli de Fatis<sup>a,b</sup>, D. Zuolo<sup>a,b</sup>

**INFN Sezione di Napoli <sup>a</sup>, Università di Napoli 'Federico II' <sup>b</sup>, Napoli, Italy, Università della Basilicata <sup>c</sup>, Potenza, Italy, Università G. Marconi <sup>d</sup>, Roma, Italy**

S. Buontempo<sup>a</sup>, N. Cavallo<sup>a,c</sup>, A. De Iorio<sup>a,b</sup>, A. Di Crescenzo<sup>a,b</sup>, F. Fabozzi<sup>a,c</sup>, F. Fienga<sup>a</sup>, A.O.M. Iorio<sup>a,b</sup>, L. Lista<sup>a,b</sup>, S. Meola<sup>a,d,15</sup>, P. Paolucci<sup>a,15</sup>, B. Rossi<sup>a</sup>, C. Sciacca<sup>a,b</sup>, E. Voevodina<sup>a,b</sup>

**INFN Sezione di Padova <sup>a</sup>, Università di Padova <sup>b</sup>, Padova, Italy, Università di Trento <sup>c</sup>, Trento, Italy**

P. Azzi<sup>a</sup>, N. Bacchetta<sup>a</sup>, D. Bisello<sup>a,b</sup>, A. Boletti<sup>a,b</sup>, A. Bragagnolo, R. Carlin<sup>a,b</sup>, P. Checchia<sup>a</sup>, M. Dall'Osso<sup>a,b</sup>, P. De Castro Manzano<sup>a</sup>, T. Dorigo<sup>a</sup>, U. Dosselli<sup>a</sup>, F. Gasparini<sup>a,b</sup>, U. Gasparini<sup>a,b</sup>, A. Gozzelino<sup>a</sup>, S.Y. Hoh, P. Lujan, M. Margoni<sup>a,b</sup>, A.T. Meneguzzo<sup>a,b</sup>, J. Pazzini<sup>a,b</sup>, M. Presilla<sup>b</sup>, P. Ronchese<sup>a,b</sup>, R. Rossin<sup>a,b</sup>, F. Simonetto<sup>a,b</sup>, A. Tiko, M. Tosi<sup>a,b</sup>, M. Zanetti<sup>a,b</sup>, P. Zotto<sup>a,b</sup>, G. Zumerle<sup>a,b</sup>

**INFN Sezione di Pavia <sup>a</sup>, Università di Pavia <sup>b</sup>, Pavia, Italy**

A. Braghieri<sup>a</sup>, P. Montagna<sup>a,b</sup>, S.P. Ratti<sup>a,b</sup>, V. Re<sup>a</sup>, M. Ressegotti<sup>a,b</sup>, C. Riccardi<sup>a,b</sup>, P. Salvini<sup>a</sup>, P. Vitulo<sup>a,b</sup>

**INFN Sezione di Perugia <sup>a</sup>, Università di Perugia <sup>b</sup>, Perugia, Italy**

M. Biasini<sup>a,b</sup>, G.M. Bilei<sup>a</sup>, C. Cecchi<sup>a,b</sup>, D. Ciangottini<sup>a,b</sup>, L. Fanò<sup>a,b</sup>, P. Lariccia<sup>a,b</sup>, R. Leonardi<sup>a,b</sup>, E. Manoni<sup>a</sup>, G. Mantovani<sup>a,b</sup>, V. Mariani<sup>a,b</sup>, M. Menichelli<sup>a</sup>, A. Rossi<sup>a,b</sup>, A. Santocchia<sup>a,b</sup>, D. Spiga<sup>a</sup>

**INFN Sezione di Pisa <sup>a</sup>, Università di Pisa <sup>b</sup>, Scuola Normale Superiore di Pisa <sup>c</sup>, Pisa, Italy**

K. Androsov<sup>a</sup>, P. Azzurri<sup>a</sup>, G. Bagliesi<sup>a</sup>, V. Bertacchi<sup>a,c</sup>, L. Bianchini<sup>a</sup>, T. Boccali<sup>a</sup>, R. Castaldi<sup>a</sup>, M.A. Ciocci<sup>a,b</sup>, R. Dell'Orso<sup>a</sup>, G. Fedi<sup>a</sup>, F. Fiori<sup>a,c</sup>, L. Giannini<sup>a,c</sup>, A. Giassi<sup>a</sup>, M.T. Grippo<sup>a</sup>, F. Ligabue<sup>a,c</sup>, E. Manca<sup>a,c</sup>, G. Mandorli<sup>a,c</sup>, A. Messineo<sup>a,b</sup>, F. Palla<sup>a</sup>, A. Rizzi<sup>a,b</sup>, G. Rolandi<sup>a,31</sup>, A. Scribano<sup>a</sup>, P. Spagnolo<sup>a</sup>, R. Tenchini<sup>a</sup>, G. Tonelli<sup>a,b</sup>, A. Venturi<sup>a</sup>, P.G. Verdini<sup>a</sup>

**INFN Sezione di Roma <sup>a</sup>, Sapienza Università di Roma <sup>b</sup>, Rome, Italy**

F. Cavallari<sup>a</sup>, M. Cipriani<sup>a,b</sup>, D. Del Re<sup>a,b</sup>, E. Di Marco<sup>a,b</sup>, M. Diemoz<sup>a</sup>, S. Gelli<sup>a,b</sup>, E. Longo<sup>a,b</sup>, B. Marzocchi<sup>a,b</sup>, P. Meridiani<sup>a</sup>, G. Organtini<sup>a,b</sup>, F. Pandolfi<sup>a</sup>, R. Paramatti<sup>a,b</sup>, F. Preiato<sup>a,b</sup>, C. Quaranta<sup>a,b</sup>, S. Rahatlou<sup>a,b</sup>, C. Rovelli<sup>a</sup>, F. Santanastasio<sup>a,b</sup>

**INFN Sezione di Torino <sup>a</sup>, Università di Torino <sup>b</sup>, Torino, Italy, Università del Piemonte Orientale <sup>c</sup>, Novara, Italy**

N. Amapane<sup>a,b</sup>, R. Arcidiacono<sup>a,c</sup>, S. Argiro<sup>a,b</sup>, M. Arneodo<sup>a,c</sup>, N. Bartosik<sup>a</sup>, R. Bellan<sup>a,b</sup>, C. Biino<sup>a</sup>, A. Cappati<sup>a,b</sup>, N. Cartiglia<sup>a</sup>, F. Cenna<sup>a,b</sup>, S. Cometti<sup>a</sup>, M. Costa<sup>a,b</sup>, R. Covarelli<sup>a,b</sup>, N. Demaria<sup>a</sup>, B. Kiani<sup>a,b</sup>, C. Mariotti<sup>a</sup>, S. Maselli<sup>a</sup>, E. Migliore<sup>a,b</sup>, V. Monaco<sup>a,b</sup>, E. Monteil<sup>a,b</sup>, M. Monteno<sup>a</sup>, M.M. Obertino<sup>a,b</sup>, L. Pacher<sup>a,b</sup>, N. Pastrone<sup>a</sup>, M. Pelliccioni<sup>a</sup>, G.L. Pinna Angioni<sup>a,b</sup>, A. Romero<sup>a,b</sup>, M. Ruspa<sup>a,c</sup>, R. Sacchi<sup>a,b</sup>, R. Salvatico<sup>a,b</sup>, K. Shchelina<sup>a,b</sup>, V. Sola<sup>a</sup>, A. Solano<sup>a,b</sup>, D. Soldi<sup>a,b</sup>, A. Staiano<sup>a</sup>

**INFN Sezione di Trieste <sup>a</sup>, Università di Trieste <sup>b</sup>, Trieste, Italy**

S. Belforte<sup>a</sup>, V. Candelise<sup>a,b</sup>, M. Casarsa<sup>a</sup>, F. Cossutti<sup>a</sup>, A. Da Rold<sup>a,b</sup>, G. Della Ricca<sup>a,b</sup>, F. Vazzoler<sup>a,b</sup>

**Kyungpook National University, Daegu, Korea**

B. Kim, D.H. Kim, G.N. Kim, M.S. Kim, J. Lee, S.W. Lee, C.S. Moon, Y.D. Oh, S.I. Pak, S. Sekmen, D.C. Son, Y.C. Yang

**Chonnam National University, Institute for Universe and Elementary Particles, Kwangju, Korea**

H. Kim, D.H. Moon, G. Oh

**Hanyang University, Seoul, Korea**

B. Francois, T.J. Kim, J. Park

**Korea University, Seoul, Korea**

S. Cho, S. Choi, Y. Go, D. Gyun, S. Ha, B. Hong, Y. Jo, K. Lee, K.S. Lee, S. Lee, J. Lim, J. Park, S.K. Park, Y. Roh

**Kyung Hee University, Department of Physics**

J. Goh

**Sejong University, Seoul, Korea**

H.S. Kim

**Seoul National University, Seoul, Korea**

J. Almond, J.H. Bhyun, J. Choi, S. Jeon, J. Kim, J.S. Kim, H. Lee, K. Lee, S. Lee, K. Nam, S.B. Oh, B.C. Radburn-Smith, S.h. Seo, U.K. Yang, H.D. Yoo, I. Yoon, G.B. Yu

**University of Seoul, Seoul, Korea**

D. Jeon, H. Kim, J.H. Kim, J.S.H. Lee, I.C. Park

**Sungkyunkwan University, Suwon, Korea**

Y. Choi, C. Hwang, Y. Jeong, J. Lee, Y. Lee, I. Yu

**Riga Technical University, Riga, Latvia**

V. Veckalns<sup>32</sup>

**Vilnius University, Vilnius, Lithuania**

V. Dudenas, A. Juodagalvis, J. Vaitkus

**National Centre for Particle Physics, Universiti Malaya, Kuala Lumpur, Malaysia**

Z.A. Ibrahim, F. Mohamad Idris<sup>33</sup>, W.A.T. Wan Abdullah, M.N. Yusli, Z. Zolkapli

**Universidad de Sonora (UNISON), Hermosillo, Mexico**

J.F. Benitez, A. Castaneda Hernandez, J.A. Murillo Quijada, L. Valencia Palomo

**Centro de Investigacion y de Estudios Avanzados del IPN, Mexico City, Mexico**

H. Castilla-Valdez, E. De La Cruz-Burelo, M.C. Duran-Osuna, I. Heredia-De La Cruz<sup>34</sup>, R. Lopez-Fernandez, C.A. Mondragon Herrera, D.A. Perez Navarro, R.I. Rabadan-Trejo, G. Ramirez-Sanchez, R. Reyes-Almanza, A. Sanchez-Hernandez

**Universidad Iberoamericana, Mexico City, Mexico**

S. Carrillo Moreno, C. Oropeza Barrera, M. Ramirez-Garcia, F. Vazquez Valencia

**Benemerita Universidad Autonoma de Puebla, Puebla, Mexico**

J. Eysermans, I. Pedraza, H.A. Salazar Ibarquen, C. Uribe Estrada

**Universidad Autónoma de San Luis Potosí, San Luis Potosí, Mexico**

A. Morelos Pineda

**University of Montenegro, Podgorica, Montenegro**

N. Raicevic

**University of Auckland, Auckland, New Zealand**

D. Krofcheck

**University of Canterbury, Christchurch, New Zealand**

S. Bheesette, P.H. Butler

**National Centre for Physics, Quaid-I-Azam University, Islamabad, Pakistan**

A. Ahmad, M. Ahmad, Q. Hassan, H.R. Hoorani, W.A. Khan, M.A. Shah, M. Shoaib, M. Waqas

**National Centre for Nuclear Research, Swierk, Poland**

H. Bialkowska, M. Bluj, B. Boimska, M. Górski, M. Kazana, M. Szeleper, P. Zalewski

**Institute of Experimental Physics, Faculty of Physics, University of Warsaw, Warsaw, Poland**

K. Bunkowski, A. Byzuk<sup>35</sup>, K. Doroba, A. Kalinowski, M. Konecki, J. Krolikowski, M. Misiura, M. Olszewski, A. Pyskir, M. Walczak

**Laboratório de Instrumentação e Física Experimental de Partículas, Lisboa, Portugal**

M. Araujo, P. Bargassa, D. Bastos, A. Di Francesco, P. Faccioli, B. Galinhas, M. Gallinaro, J. Hollar, N. Leonardo, J. Seixas, G. Strong, O. Toldaiev, J. Varela

**Joint Institute for Nuclear Research, Dubna, Russia**

S. Afanasiev, P. Bunin, M. Gavrilenko, I. Golutvin, I. Gorbunov, A. Kamenev, V. Karjavine, A. Lanev, A. Malakhov, V. Matveev<sup>36,37</sup>, P. Moiseenz, V. Palichik, V. Perelygin, M. Savina, S. Shmatov, S. Shulha, N. Skatchkov, V. Smirnov, N. Voytishin, A. Zarubin

**Petersburg Nuclear Physics Institute, Gatchina (St. Petersburg), Russia**

L. Chtchypounov, V. Golovtsov, Y. Ivanov, V. Kim<sup>38</sup>, E. Kuznetsova<sup>39</sup>, P. Levchenko, V. Murzin, V. Oreshkin, I. Smirnov, D. Sosnov, V. Sulimov, L. Uvarov, A. Vorobyev

**Institute for Nuclear Research, Moscow, Russia**

Yu. Andreev, A. Dermenev, S. Gninenko, N. Golubev, A. Karneyeu, M. Kirsanov, N. Krasnikov, A. Pashenkov, D. Tlisov, A. Toropin

**Institute for Theoretical and Experimental Physics, Moscow, Russia**

V. Epshteyn, V. Gavrilov, N. Lychkovskaya, A. Nikitenko<sup>8</sup>, V. Popov, I. Pozdnyakov, G. Safronov, A. Spiridonov, A. Stepenov, M. Toms, E. Vlasov, A. Zhokin

**Moscow Institute of Physics and Technology, Moscow, Russia**

T. Aushev

**National Research Nuclear University 'Moscow Engineering Physics Institute' (MEPhI), Moscow, Russia**

R. Chistov<sup>40</sup>, M. Danilov<sup>40</sup>, S. Polikarpov<sup>40</sup>, E. Tarkovskii

**P.N. Lebedev Physical Institute, Moscow, Russia**

V. Andreev, M. Azarkin, I. Dremin<sup>37</sup>, M. Kirakosyan, A. Terkulov

**Skobeltsyn Institute of Nuclear Physics, Lomonosov Moscow State University, Moscow, Russia**

A. Belyaev, E. Boos, M. Dubinin<sup>41</sup>, L. Dudko, A. Ershov, A. Gribushin, V. Klyukhin, O. Kodolova, I. Lokhtin, S. Obraztsov, S. Petrushanko, V. Savrin, A. Snigirev

**Novosibirsk State University (NSU), Novosibirsk, Russia**

A. Barnyakov<sup>42</sup>, V. Blinov<sup>42</sup>, T. Dimova<sup>42</sup>, L. Kardapol'tsev<sup>42</sup>, Y. Skovpen<sup>42</sup>

**Institute for High Energy Physics of National Research Centre 'Kurchatov Institute', Protvino, Russia**

I. Azhgirey, I. Bayshev, S. Bitioukov, V. Kachanov, D. Konstantinov, P. Mandrik, V. Petrov, R. Ryutin, S. Slabospitskii, A. Sobol, S. Troshin, N. Tyurin, A. Uzunian, A. Volkov

**National Research Tomsk Polytechnic University, Tomsk, Russia**

A. Babaev, A. Iuzhakov, V. Okhotnikov

**Tomsk State University**

V. Ivanchenko, E. Tcherniaev

**University of Belgrade, Faculty of Physics and Vinca Institute of Nuclear Sciences, Belgrade, Serbia**

P. Adzic<sup>43</sup>, P. Cirkovic, D. Devetak, M. Dordevic, P. Milenovic<sup>44</sup>, J. Milosevic, M. Stojanovic

**Centro de Investigaciones Energéticas Medioambientales y Tecnológicas (CIEMAT), Madrid, Spain**

M. Aguilar-Benitez, J. Alcaraz Maestre, A. Álvarez Fernández, I. Bachiller, M. Barrio Luna, J.A. Brochero Cifuentes, C.A. Carrillo Montoya, M. Cepeda, M. Cerrada, N. Colino, B. De La Cruz, A. Delgado Peris, C. Fernandez Bedoya, J.P. Fernández Ramos, J. Flix, M.C. Fouz, O. Gonzalez Lopez, S. Goy Lopez, J.M. Hernandez, M.I. Josa, D. Moran, Á. Navarro Tobar, A. Pérez-Calero Yzquierdo, J. Puerta Pelayo, I. Redondo, L. Romero, S. Sánchez Navas, M.S. Soares, A. Triossi, C. Willmott

**Universidad Autónoma de Madrid, Madrid, Spain**

C. Albajar, J.F. de Trocóniz

**Universidad de Oviedo, Oviedo, Spain**

J. Cuevas, C. Erice, J. Fernandez Menendez, S. Folgueras, I. Gonzalez Caballero, J.R. González Fernández, E. Palencia Cortezon, V. Rodríguez Bouza, S. Sanchez Cruz, J.M. Vizan Garcia

**Instituto de Física de Cantabria (IFCA), CSIC-Universidad de Cantabria, Santander, Spain**

I.J. Cabrillo, A. Calderon, B. Chazin Quero, J. Duarte Campderros, M. Fernandez,

P.J. Fernández Manteca, A. García Alonso, G. Gomez, C. Martinez Rivero, P. Martinez Ruiz del Arbol, F. Matorras, J. Piedra Gomez, C. Prieels, T. Rodrigo, A. Ruiz-Jimeno, L. Scodellaro, N. Trevisani, I. Vila

**University of Colombo, Colombo, Sri Lanka**

K. Malagalage

**University of Ruhuna, Department of Physics, Matara, Sri Lanka**

W.G.D. Dharmaratna, N. Wickramage

**CERN, European Organization for Nuclear Research, Geneva, Switzerland**

D. Abbaneo, B. Akgun, E. Auffray, G. Auzinger, P. Baillon, A.H. Ball, D. Barney, J. Bendavid, M. Bianco, A. Bocci, C. Botta, E. Brondolin, T. Camporesi, A. Caratelli, G. Cerminara, E. Chapon, G. Cucciati, D. d'Enterria, A. Dabrowski, N. Daci, V. Daponte, A. David, A. De Roeck, N. Deelen, M. Dobson, M. Dünser, N. Dupont, A. Elliott-Peisert, F. Fallavollita<sup>45</sup>, D. Fasanella, G. Franzoni, J. Fulcher, W. Funk, D. Gigi, A. Gilbert, K. Gill, F. Glege, M. Gruchala, M. Guilbaud, D. Gulhan, J. Hegeman, C. Heidegger, Y. Iiyama, V. Innocente, A. Jafari, P. Janot, O. Karacheban<sup>18</sup>, J. Kieseler, M. Krammer<sup>1</sup>, C. Lange, P. Lecoq, C. Lourenço, L. Malgeri, M. Mannelli, A. Massironi, F. Meijers, J.A. Merlin, S. Mersi, E. Meschi, F. Moortgat, M. Mulders, J. Ngadiuba, S. Nourbakhsh, S. Orfanelli, L. Orsini, F. Pantaleo<sup>15</sup>, L. Pape, E. Perez, M. Peruzzi, A. Petrilli, G. Petrucciani, A. Pfeiffer, M. Pierini, F.M. Pitters, D. Rabady, A. Racz, M. Rovere, H. Sakulin, C. Schäfer, C. Schwick, M. Selvaggi, A. Sharma, P. Silva, P. Sphicas<sup>46</sup>, A. Stakia, J. Steggemann, V.R. Tavolaro, D. Treille, A. Tsirou, A. Vartak, M. Verzetti, W.D. Zeuner

**Paul Scherrer Institut, Villigen, Switzerland**

L. Caminada<sup>47</sup>, K. Deiters, W. Erdmann, R. Horisberger, Q. Ingram, H.C. Kaestli, D. Kotlinski, U. Langenegger, T. Rohe, S.A. Wiederkehr

**ETH Zurich - Institute for Particle Physics and Astrophysics (IPA), Zurich, Switzerland**

M. Backhaus, P. Berger, N. Chernyavskaya, G. Dissertori, M. Dittmar, M. Donegà, C. Dorfer, T.A. Gómez Espinosa, C. Grab, D. Hits, T. Klijnsma, W. Lustermann, R.A. Manzoni, M. Marionneau, M.T. Meinhard, F. Micheli, P. Musella, F. Nessi-Tedaldi, F. Pauss, G. Perrin, L. Perrozzi, S. Pigazzini, M. Reichmann, C. Reissel, T. Reitenspiess, D. Ruini, D.A. Sanz Becerra, M. Schönenberger, L. Shchutska, M.L. Vesterbacka Olsson, R. Wallny, D.H. Zhu

**Universität Zürich, Zurich, Switzerland**

T.K. Aarrestad, C. Amsler<sup>48</sup>, D. Brzhechko, M.F. Canelli, A. De Cosa, R. Del Burgo, S. Donato, C. Galloni, B. Kilminster, S. Leontsinis, V.M. Mikuni, I. Neutelings, G. Rauco, P. Robmann, D. Salerno, K. Schweiger, C. Seitz, Y. Takahashi, S. Wertz, A. Zucchetta

**National Central University, Chung-Li, Taiwan**

T.H. Doan, C.M. Kuo, W. Lin, S.S. Yu

**National Taiwan University (NTU), Taipei, Taiwan**

P. Chang, Y. Chao, K.F. Chen, P.H. Chen, W.-S. Hou, Y.y. Li, R.-S. Lu, E. Paganis, A. Psallidas, A. Steen

**Chulalongkorn University, Faculty of Science, Department of Physics, Bangkok, Thailand**

B. Asavapibhop, N. Srimanobhas, N. Suwonjandee

**Çukurova University, Physics Department, Science and Art Faculty, Adana, Turkey**

A. Bat, F. Boran, S. Cerci<sup>49</sup>, S. Damarseckin<sup>50</sup>, Z.S. Demiroglu, F. Dolek, C. Dozen, I. Dumanoglu, G. Gokbulut, EmineGurpinar Guler<sup>51</sup>, Y. Guler, I. Hos<sup>52</sup>, C. Isik, E.E. Kangal<sup>53</sup>,

O. Kara, A. Kayis Topaksu, U. Kiminsu, M. Oglakci, G. Onengut, K. Ozdemir<sup>54</sup>, S. Ozturk<sup>55</sup>, A.E. Simsek, D. Sunar Cerci<sup>49</sup>, U.G. Tok, S. Turkcapar, I.S. Zorbakir, C. Zorbilmez

**Middle East Technical University, Physics Department, Ankara, Turkey**

B. Isildak<sup>56</sup>, G. Karapinar<sup>57</sup>, M. Yalvac

**Bogazici University, Istanbul, Turkey**

I.O. Atakisi, E. Gülmez, O. Kaya<sup>58</sup>, B. Kaynak, Ö. Özçelik, S. Ozkorucuklu<sup>59</sup>, S. Tekten, E.A. Yetkin<sup>60</sup>

**Istanbul Technical University, Istanbul, Turkey**

A. Cakir, Y. Komurcu, S. Sen<sup>61</sup>

**Institute for Scintillation Materials of National Academy of Science of Ukraine, Kharkov, Ukraine**

B. Grynyov

**National Scientific Center, Kharkov Institute of Physics and Technology, Kharkov, Ukraine**

L. Levchuk

**University of Bristol, Bristol, United Kingdom**

F. Ball, E. Bhal, S. Bologna, J.J. Brooke, D. Burns, E. Clement, D. Cussans, O. Davignon, H. Flacher, J. Goldstein, G.P. Heath, H.F. Heath, L. Kreczko, S. Paramesvaran, B. Penning, T. Sakuma, S. Seif El Nasr-Storey, D. Smith, V.J. Smith, J. Taylor, A. Titterton

**Rutherford Appleton Laboratory, Didcot, United Kingdom**

K.W. Bell, A. Belyaev<sup>62</sup>, C. Brew, R.M. Brown, D. Cieri, D.J.A. Cockerill, J.A. Coughlan, K. Harder, S. Harper, J. Linacre, K. Manolopoulos, D.M. Newbold<sup>63</sup>, E. Olaiya, D. Petyt, T. Reis, T. Schuh, C.H. Shepherd-Themistocleous, A. Thea, I.R. Tomalin, T. Williams, W.J. Womersley

**Imperial College, London, United Kingdom**

R. Bainbridge, P. Bloch, J. Borg, S. Breeze, O. Buchmuller, A. Bundock, GurpreetSingh CHAHAL<sup>64</sup>, D. Colling, P. Dauncey, G. Davies, M. Della Negra, R. Di Maria, P. Everaerts, G. Hall, G. Iles, T. James, M. Komm, C. Laner, L. Lyons, A.-M. Magnan, S. Malik, A. Martelli, V. Milosevic, J. Nash<sup>65</sup>, V. Palladino, M. Pesaresi, D.M. Raymond, A. Richards, A. Rose, E. Scott, C. Seez, A. Shtipliyski, M. Stoye, T. Strebler, S. Summers, A. Tapper, K. Uchida, T. Virdee<sup>15</sup>, N. Wardle, D. Winterbottom, J. Wright, A.G. Zecchinelli, S.C. Zenz

**Brunel University, Uxbridge, United Kingdom**

J.E. Cole, P.R. Hobson, A. Khan, P. Kyberd, C.K. Mackay, A. Morton, I.D. Reid, L. Teodorescu, S. Zahid

**Baylor University, Waco, USA**

K. Call, J. Dittmann, K. Hatakeyama, C. Madrid, B. McMaster, N. Pastika, C. Smith

**Catholic University of America, Washington, DC, USA**

R. Bartek, A. Dominguez, R. Uniyal

**The University of Alabama, Tuscaloosa, USA**

A. Buccilli, S.I. Cooper, C. Henderson, P. Rumerio, C. West

**Boston University, Boston, USA**

D. Arcaro, T. Bose, Z. Demiragli, D. Gastler, S. Girgis, D. Pinna, C. Richardson, J. Rohlf, D. Sperka, I. Suarez, L. Sulak, D. Zou

**Brown University, Providence, USA**

G. Benelli, B. Burkle, X. Coubez, D. Cutts, M. Hadley, J. Hakala, U. Heintz, J.M. Hogan<sup>66</sup>, K.H.M. Kwok, E. Laird, G. Landsberg, J. Lee, Z. Mao, M. Narain, S. Sagir<sup>67</sup>, R. Syarif, E. Usai, D. Yu

**University of California, Davis, Davis, USA**

R. Band, C. Brainerd, R. Breedon, M. Calderon De La Barca Sanchez, M. Chertok, J. Conway, R. Conway, P.T. Cox, R. Erbacher, C. Flores, G. Funk, F. Jensen, W. Ko, O. Kukral, R. Lander, M. Mulhearn, D. Pellett, J. Pilot, M. Shi, D. Stolp, D. Taylor, K. Tos, M. Tripathi, Z. Wang, F. Zhang

**University of California, Los Angeles, USA**

M. Bachtis, C. Bravo, R. Cousins, A. Dasgupta, A. Florent, J. Hauser, M. Ignatenko, N. Mccoll, S. Regnard, D. Saltzberg, C. Schnaible, V. Valuev

**University of California, Riverside, Riverside, USA**

K. Burt, R. Clare, J.W. Gary, S.M.A. Ghiasi Shirazi, G. Hanson, G. Karapostoli, E. Kennedy, O.R. Long, M. Olmedo Negrete, M.I. Paneva, W. Si, L. Wang, H. Wei, S. Wimpenny, B.R. Yates, Y. Zhang

**University of California, San Diego, La Jolla, USA**

J.G. Branson, P. Chang, S. Cittolin, M. Derdzinski, R. Gerosa, D. Gilbert, B. Hashemi, D. Klein, V. Krutelyov, J. Letts, M. Masciovecchio, S. May, S. Padhi, M. Pieri, V. Sharma, M. Tadel, F. Würthwein, A. Yagil, G. Zevi Della Porta

**University of California, Santa Barbara - Department of Physics, Santa Barbara, USA**

N. Amin, R. Bhandari, C. Campagnari, M. Citron, V. Dutta, M. Franco Sevilla, L. Gouskos, J. Incandela, B. Marsh, H. Mei, A. Ovcharova, H. Qu, J. Richman, U. Sarica, D. Stuart, S. Wang, J. Yoo

**California Institute of Technology, Pasadena, USA**

D. Anderson, A. Bornheim, J.M. Lawhorn, N. Lu, H.B. Newman, T.Q. Nguyen, J. Pata, M. Spiropulu, J.R. Vlimant, S. Xie, Z. Zhang, R.Y. Zhu

**Carnegie Mellon University, Pittsburgh, USA**

M.B. Andrews, T. Ferguson, T. Mudholkar, M. Paulini, M. Sun, I. Vorobiev, M. Weinberg

**University of Colorado Boulder, Boulder, USA**

J.P. Cumalat, W.T. Ford, A. Johnson, E. MacDonald, T. Mulholland, R. Patel, A. Perloff, K. Stenson, K.A. Ulmer, S.R. Wagner

**Cornell University, Ithaca, USA**

J. Alexander, J. Chaves, Y. Cheng, J. Chu, A. Datta, A. Frankenthal, K. Mcdermott, N. Mirman, J.R. Patterson, D. Quach, A. Rinkevicius, A. Ryd, S.M. Tan, Z. Tao, J. Thom, P. Wittich, M. Zientek

**Fermi National Accelerator Laboratory, Batavia, USA**

S. Abdullin, M. Albrow, M. Alyari, G. Apollinari, A. Apresyan, A. Apyan, S. Banerjee, L.A.T. Bauerdick, A. Beretvas, J. Berryhill, P.C. Bhat, K. Burkett, J.N. Butler, A. Canepa, G.B. Cerati, H.W.K. Cheung, F. Chlebana, M. Cremonesi, J. Duarte, V.D. Elvira, J. Freeman, Z. Gecse, E. Gottschalk, L. Gray, D. Green, S. Grünendahl, O. Gutsche, AllisonReinsvold Hall, J. Hanlon, R.M. Harris, S. Hasegawa, R. Heller, J. Hirschauer, Z. Hu, B. Jayatilaka, S. Jindariani, M. Johnson, U. Joshi, B. Klima, M.J. Kortelainen, B. Kreis, S. Lammel, J. Lewis, D. Lincoln, R. Lipton, M. Liu, T. Liu, J. Lykken, K. Maeshima, J.M. Marraffino, D. Mason, P. McBride,



P. Merkel, S. Mrenna, S. Nahn, V. O'Dell, V. Papadimitriou, K. Pedro, C. Pena, G. Rakness, F. Ravera, L. Ristori, B. Schneider, E. Sexton-Kennedy, N. Smith, A. Soha, W.J. Spalding, L. Spiegel, S. Stoynev, J. Strait, N. Strobbe, L. Taylor, S. Tkaczyk, N.V. Tran, L. Uplegger, E.W. Vaandering, C. Vernieri, M. Verzocchi, R. Vidal, M. Wang, H.A. Weber

**University of Florida, Gainesville, USA**

D. Acosta, P. Avery, P. Bortignon, D. Bourilkov, A. Brinkerhoff, L. Cadamuro, A. Carnes, V. Cherepanov, D. Curry, F. Errico, R.D. Field, S.V. Gleyzer, B.M. Joshi, M. Kim, J. Konigsberg, A. Korytov, K.H. Lo, P. Ma, K. Matchev, N. Menendez, G. Mitselmakher, D. Rosenzweig, K. Shi, J. Wang, S. Wang, X. Zuo

**Florida International University, Miami, USA**

Y.R. Joshi, S. Linn

**Florida State University, Tallahassee, USA**

T. Adams, A. Askew, S. Hagopian, V. Hagopian, K.F. Johnson, T. Kolberg, G. Martinez, H. Prosper, C. Schiber, R. Yohay

**Florida Institute of Technology, Melbourne, USA**

M.M. Baarmand, V. Bhopatkar, M. Hohlmann, D. Noonan, M. Rahmani, M. Saunders, F. Yumiceva

**University of Illinois at Chicago (UIC), Chicago, USA**

M.R. Adams, L. Apanasevich, D. Berry, R.R. Betts, R. Cavanaugh, X. Chen, S. Dittmer, O. Evdokimov, C.E. Gerber, D.A. Hangal, D.J. Hofman, K. Jung, C. Mills, T. Roy, M.B. Tonjes, N. Varelas, H. Wang, X. Wang, Z. Wu, J. Zhang

**The University of Iowa, Iowa City, USA**

M. Alhusseini, B. Bilki<sup>51</sup>, W. Clarida, K. Dilsiz<sup>68</sup>, S. Durgut, R.P. Gandrajula, M. Haytmyradov, V. Khristenko, O.K. Köseyan, J.-P. Merlo, A. Mestvirishvili, A. Moeller, J. Nachtman, H. Ogul<sup>69</sup>, Y. Onel, F. Ozok<sup>70</sup>, A. Penzo, C. Snyder, E. Tiras, J. Wetzel

**Johns Hopkins University, Baltimore, USA**

B. Blumenfeld, A. Cocoros, N. Eminizer, D. Fehling, L. Feng, A.V. Gritsan, W.T. Hung, P. Maksimovic, J. Roskes, M. Swartz, M. Xiao

**The University of Kansas, Lawrence, USA**

C. Baldenegro Barrera, P. Baringer, A. Bean, S. Boren, J. Bowen, A. Bylinkin, T. Isidori, S. Khalil, J. King, A. Kropivnitskaya, D. Majumder, W. Mcbrayer, N. Minafra, M. Murray, C. Rogan, C. Royon, S. Sanders, E. Schmitz, J.D. Tapia Takaki, Q. Wang, J. Williams

**Kansas State University, Manhattan, USA**

S. Duric, A. Ivanov, K. Kaadze, D. Kim, Y. Maravin, D.R. Mendis, T. Mitchell, A. Mohammadi

**Lawrence Livermore National Laboratory, Livermore, USA**

F. Rebassoo, D. Wright

**University of Maryland, College Park, USA**

A. Baden, O. Baron, A. Belloni, S.C. Eno, Y. Feng, C. Ferraioli, N.J. Hadley, S. Jabeen, G.Y. Jeng, R.G. Kellogg, J. Kunkle, A.C. Mignerey, S. Nabili, F. Ricci-Tam, M. Seidel, Y.H. Shin, A. Skuja, S.C. Tonwar, K. Wong

**Massachusetts Institute of Technology, Cambridge, USA**

D. Abercrombie, B. Allen, A. Baty, R. Bi, S. Brandt, W. Busza, I.A. Cali, M. D'Alfonso, G. Gomez Ceballos, M. Goncharov, P. Harris, D. Hsu, M. Hu, M. Klute, D. Kovalskyi, Y.-J. Lee,

P.D. Luckey, B. Maier, A.C. Marini, C. McGinn, C. Mironov, S. Narayanan, X. Niu, C. Paus, D. Rankin, C. Roland, G. Roland, Z. Shi, G.S.F. Stephans, K. Sumorok, K. Tatar, D. Velicanu, J. Wang, T.W. Wang, B. Wyslouch

**University of Minnesota, Minneapolis, USA**

A.C. Benvenuti<sup>†</sup>, R.M. Chatterjee, A. Evans, P. Hansen, J. Hiltbrand, S. Kalafut, Y. Kubota, Z. Lesko, J. Mans, R. Rusack, M.A. Wadud

**University of Mississippi, Oxford, USA**

J.G. Acosta, S. Oliveros

**University of Nebraska-Lincoln, Lincoln, USA**

E. Avdeeva, K. Bloom, D.R. Claes, C. Fangmeier, L. Finco, F. Golf, R. Gonzalez Suarez, R. Kamalieddin, I. Kravchenko, J.E. Siado, G.R. Snow, B. Stieger

**State University of New York at Buffalo, Buffalo, USA**

A. Godshalk, C. Harrington, I. Iashvili, A. Kharchilava, C. Mclean, D. Nguyen, A. Parker, S. Rappoccio, B. Roozbahani

**Northeastern University, Boston, USA**

G. Alverson, E. Barberis, C. Freer, Y. Haddad, A. Hortiangtham, G. Madigan, D.M. Morse, T. Orimoto, L. Skinnari, A. Tishelman-Charny, T. Wamorkar, B. Wang, A. Wisecarver, D. Wood

**Northwestern University, Evanston, USA**

J. Bueghly, T. Gunter, K.A. Hahn, M.H. Schmitt, K. Sung, M. Trovato, M. Velasco

**University of Notre Dame, Notre Dame, USA**

R. Bucci, N. Dev, R. Goldouzian, M. Hildreth, K. Hurtado Anampa, C. Jessop, D.J. Karmgard, K. Lannon, W. Li, N. Loukas, N. Marinelli, I. Mcalister, F. Meng, C. Mueller, Y. Musienko<sup>36</sup>, M. Planer, R. Ruchti, P. Siddireddy, G. Smith, S. Taroni, M. Wayne, A. Wightman, M. Wolf, A. Woodard

**The Ohio State University, Columbus, USA**

J. Alimena, B. Bylsma, L.S. Durkin, S. Flowers, B. Francis, C. Hill, W. Ji, A. Lefeld, T.Y. Ling, B.L. Winer

**Princeton University, Princeton, USA**

S. Cooperstein, G. Dezoort, P. Elmer, N. Haubrich, S. Higginbotham, A. Kalogeropoulos, S. Kwan, D. Lange, M.T. Lucchini, J. Luo, D. Marlow, K. Mei, I. Ojalvo, J. Olsen, C. Palmer, P. Piroué, J. Salfeld-Nebgen, D. Stickland, C. Tully, Z. Wang

**University of Puerto Rico, Mayaguez, USA**

S. Malik, S. Norberg

**Purdue University, West Lafayette, USA**

A. Barker, V.E. Barnes, S. Das, L. Gutay, M. Jones, A.W. Jung, A. Khatiwada, B. Mahakud, D.H. Miller, G. Negro, N. Neumeister, C.C. Peng, S. Piperov, H. Qiu, J.F. Schulte, J. Sun, F. Wang, R. Xiao, W. Xie

**Purdue University Northwest, Hammond, USA**

T. Cheng, J. Dolen, N. Parashar

**Rice University, Houston, USA**

K.M. Ecklund, S. Freed, F.J.M. Geurts, M. Kilpatrick, Arun Kumar, W. Li, B.P. Padley, R. Redjimi, J. Roberts, J. Rorie, W. Shi, A.G. Stahl Leiton, Z. Tu, A. Zhang

**University of Rochester, Rochester, USA**

A. Bodek, P. de Barbaro, R. Demina, Y.t. Duh, J.L. Dulemba, C. Fallon, T. Ferbel, M. Galanti, A. Garcia-Bellido, J. Han, O. Hindrichs, A. Khukhunaishvili, E. Ranken, P. Tan, R. Taus

**Rutgers, The State University of New Jersey, Piscataway, USA**

B. Chiarito, J.P. Chou, Y. Gershtein, E. Halkiadakis, A. Hart, M. Heindl, E. Hughes, S. Kaplan, S. Kyriacou, I. Laflotte, A. Lath, R. Montalvo, K. Nash, M. Osherson, H. Saka, S. Salur, S. Schnetzer, D. Sheffield, S. Somalwar, R. Stone, S. Thomas, P. Thomassen

**University of Tennessee, Knoxville, USA**

H. Acharya, A.G. Delannoy, J. Heideman, G. Riley, S. Spanier

**Texas A&M University, College Station, USA**

O. Bouhali<sup>71</sup>, A. Celik, M. Dalchenko, M. De Mattia, A. Delgado, S. Dildick, R. Eusebi, J. Gilmore, T. Huang, T. Kamon<sup>72</sup>, S. Luo, D. Marley, R. Mueller, D. Overton, L. Perniè, D. Rathjens, A. Safonov

**Texas Tech University, Lubbock, USA**

N. Akchurin, J. Damgov, F. De Guio, S. Kunori, K. Lamichhane, S.W. Lee, T. Mengke, S. Muthumuni, T. Peltola, S. Undleeb, I. Volobouev, Z. Wang, A. Whitbeck

**Vanderbilt University, Nashville, USA**

S. Greene, A. Gurrola, R. Janjam, W. Johns, C. Maguire, H. Ni, F. Romeo, P. Sheldon, S. Tuo, J. Velkovska, M. Verweij

**University of Virginia, Charlottesville, USA**

M.W. Arenton, P. Barria, B. Cox, G. Cummings, R. Hirosky, M. Joyce, A. Ledovskoy, C. Neu, B. Tannenwald, Y. Wang, E. Wolfe, F. Xia

**Wayne State University, Detroit, USA**

R. Harr, P.E. Karchin, N. Poudyal, J. Sturdy, P. Thapa, S. Zaleski

**University of Wisconsin - Madison, Madison, WI, USA**

J. Buchanan, C. Caillol, D. Carlsmith, S. Dasu, I. De Bruyn, L. Dodd, B. Gombert<sup>73</sup>, M. Grothe, M. Herndon, A. Hervé, U. Hussain, P. Klabbers, A. Lanaro, K. Long, R. Loveless, T. Ruggles, A. Savin, V. Sharma, W.H. Smith, N. Woods

†: Deceased

1: Also at Vienna University of Technology, Vienna, Austria

2: Also at IRFU, CEA, Université Paris-Saclay, Gif-sur-Yvette, France

3: Also at Universidade Estadual de Campinas, Campinas, Brazil

4: Also at Federal University of Rio Grande do Sul, Porto Alegre, Brazil

5: Also at Universidade Federal de Pelotas, Pelotas, Brazil

6: Also at Université Libre de Bruxelles, Bruxelles, Belgium

7: Also at University of Chinese Academy of Sciences, Beijing, China

8: Also at Institute for Theoretical and Experimental Physics, Moscow, Russia

9: Also at Joint Institute for Nuclear Research, Dubna, Russia

10: Also at Suez University, Suez, Egypt

11: Now at British University in Egypt, Cairo, Egypt

12: Also at Purdue University, West Lafayette, USA

13: Also at Université de Haute Alsace, Mulhouse, France

14: Also at Tbilisi State University, Tbilisi, Georgia

15: Also at CERN, European Organization for Nuclear Research, Geneva, Switzerland

16: Also at RWTH Aachen University, III. Physikalisches Institut A, Aachen, Germany

- 17: Also at University of Hamburg, Hamburg, Germany
- 18: Also at Brandenburg University of Technology, Cottbus, Germany
- 19: Also at Institute of Physics, University of Debrecen, Debrecen, Hungary
- 20: Also at Institute of Nuclear Research ATOMKI, Debrecen, Hungary
- 21: Also at MTA-ELTE Lendület CMS Particle and Nuclear Physics Group, Eötvös Loránd University, Budapest, Hungary
- 22: Also at Indian Institute of Technology Bhubaneswar, Bhubaneswar, India
- 23: Also at Institute of Physics, Bhubaneswar, India
- 24: Also at Shoolini University, Solan, India
- 25: Also at University of Visva-Bharati, Santiniketan, India
- 26: Also at Isfahan University of Technology, Isfahan, Iran
- 27: Also at Plasma Physics Research Center, Science and Research Branch, Islamic Azad University, Tehran, Iran
- 28: Also at ITALIAN NATIONAL AGENCY FOR NEW TECHNOLOGIES, ENERGY AND SUSTAINABLE ECONOMIC DEVELOPMENT, Bologna, Italy
- 29: Also at CENTRO SICILIANO DI FISICA NUCLEARE E DI STRUTTURA DELLA MATERIA, Catania, Italy
- 30: Also at Università degli Studi di Siena, Siena, Italy
- 31: Also at Scuola Normale e Sezione dell'INFN, Pisa, Italy
- 32: Also at Riga Technical University, Riga, Latvia
- 33: Also at Malaysian Nuclear Agency, MOSTI, Kajang, Malaysia
- 34: Also at Consejo Nacional de Ciencia y Tecnología, Mexico City, Mexico
- 35: Also at Warsaw University of Technology, Institute of Electronic Systems, Warsaw, Poland
- 36: Also at Institute for Nuclear Research, Moscow, Russia
- 37: Now at National Research Nuclear University 'Moscow Engineering Physics Institute' (MEPhI), Moscow, Russia
- 38: Also at St. Petersburg State Polytechnical University, St. Petersburg, Russia
- 39: Also at University of Florida, Gainesville, USA
- 40: Also at P.N. Lebedev Physical Institute, Moscow, Russia
- 41: Also at California Institute of Technology, Pasadena, USA
- 42: Also at Budker Institute of Nuclear Physics, Novosibirsk, Russia
- 43: Also at Faculty of Physics, University of Belgrade, Belgrade, Serbia
- 44: Also at University of Belgrade, Faculty of Physics and Vinca Institute of Nuclear Sciences, Belgrade, Serbia
- 45: Also at INFN Sezione di Pavia <sup>a</sup>, Università di Pavia <sup>b</sup>, Pavia, Italy
- 46: Also at National and Kapodistrian University of Athens, Athens, Greece
- 47: Also at Universität Zürich, Zurich, Switzerland
- 48: Also at Stefan Meyer Institute for Subatomic Physics (SMI), Vienna, Austria
- 49: Also at Adiyaman University, Adiyaman, Turkey
- 50: Also at Sirtak University, SIRTAK, Turkey
- 51: Also at Beykent University, Istanbul, Turkey
- 52: Also at Istanbul Aydin University, Istanbul, Turkey
- 53: Also at Mersin University, Mersin, Turkey
- 54: Also at Piri Reis University, Istanbul, Turkey
- 55: Also at Gaziosmanpasa University, Tokat, Turkey
- 56: Also at Ozyegin University, Istanbul, Turkey
- 57: Also at Izmir Institute of Technology, Izmir, Turkey
- 58: Also at Kafkas University, Kars, Turkey
- 59: Also at Istanbul University, Faculty of Science, Istanbul, Turkey

60: Also at Istanbul Bilgi University, Istanbul, Turkey

61: Also at Hacettepe University, Ankara, Turkey

62: Also at School of Physics and Astronomy, University of Southampton, Southampton, United Kingdom

63: Also at Rutherford Appleton Laboratory, Didcot, United Kingdom

64: Also at Institute for Particle Physics Phenomenology Durham University, Durham, United Kingdom

65: Also at Monash University, Faculty of Science, Clayton, Australia

66: Also at Bethel University, St. Paul, USA

67: Also at Karamanoğlu Mehmetbey University, Karaman, Turkey

68: Also at Bingol University, Bingol, Turkey

69: Also at Sinop University, Sinop, Turkey

70: Also at Mimar Sinan University, Istanbul, Istanbul, Turkey

71: Also at Texas A&M University at Qatar, Doha, Qatar

72: Also at Kyungpook National University, Daegu, Korea

73: Also at University of Hyderabad, Hyderabad, India